

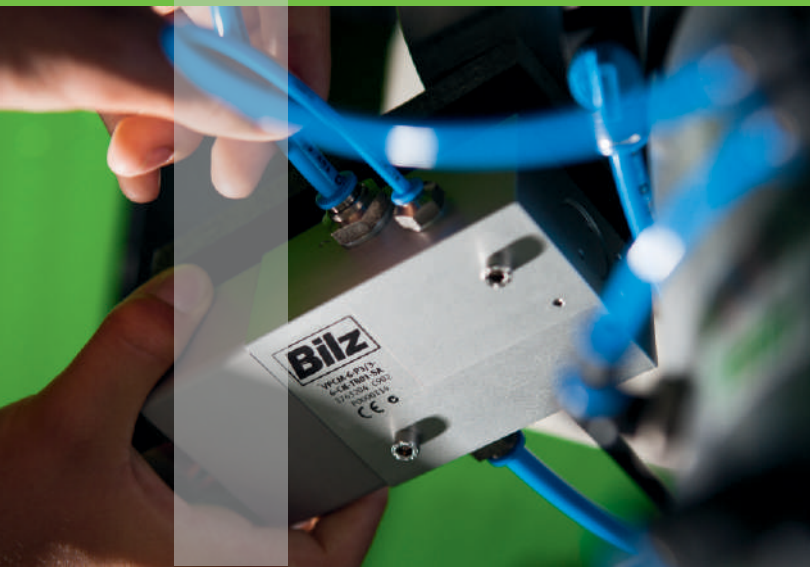

**General
Catalogue**

Your Expert for
Vibration Insulation
and Machine Leveling Technology

When solutions are required quality makes the difference.



Bilz Vibration Technology AG is based in Leonberg, Germany. Bilz has specialized in machine mounting technology with a focus on vibration isolation. Bilz is Europe's leading anti-vibration specialists supplying products and services to machine and equipment manufacturers as well as automobile industry worldwide. Vibration isolation is always an issue when it comes to precision machining or measurement. 45 years of experience in the field of vibration technology enables Bilz to offer a wide range of solutions. These solutions include: simple isolation pads, rubber & membrane air springs, mechanical & electro-pneumatic level control systems & active vibration cancellation systems, special machine foundations and vibration measurement and analysis

Machine House (India) Pvt Ltd, based in Nashik India, is associated with Bilz for more than 2 decades, mainly for manufacturing (exports to Bilz, Germany) and marketing & sales in India. Extensive technical support from Bilz combined with rich manufacturing and marketing experience has established Machine House as a pioneer in the field of high quality anti vibration solutions. Powered by a highly trained sales and design team in Nashik along with an established dealer network in all major industrial cities in India, Machine House is equipped to undertake critical vibration isolation projects dealing with precision machining and measurements.

'Effective and cost efficient solutions for nearly every problem caused by vibration', A claim that Bilz Vibration Technology and Machine House (India) Pvt Ltd meet very successfully every day worldwide !



Your benefits from Bilz technology and know-how

- Optimum vibration and structure-borne noise isolation
- Effective protection of people, environment and buildings
- Quality improvements through reduced manufacturing tolerances and increased manufacturing precision
- Increased production throughput by shortening cycle times in production
- Cost reductions through simplified and flexible machine installation
- Quality and safety through compliance with the latest standards, directives and guidelines
 - DIN ISO 9001
 - EC Machinery Directive
 - EC Low Voltage Directive
 - EC EMC Directive

Content

General	1 - 2
Insulation pads	3 - 8
Leveling Mounts	9 - 13
Precision Leveling Wedges	14 - 20
FAEBI® Rubber Air Springs	21 - 27
BiAir® Membrane Air Springs	28 - 30
Level Control	31 - 32
Vibration Isolation Tables	33 - 37
Indirect Isolation	38 - 48
Vibration Measurement	49 - 50

General information on vibration technology

Demands on the design and operation of modern machinery and equipment continue to escalate. The technical capabilities of today's machines in terms of machining speed, dynamic load changes and achievable precision, as well as the key features of the geometry and the properties of the materials used have grown steadily over recent years. However, this also increases the need to reduce the transmitted vibrations and structure-borne noise. This concerns both the emission of vibrations (source insulation), for example in metal-working machines, as well as machines being subject to vibrations (receiver insulation), e.g. in measuring machines. The importance of measures to protect people, buildings and the environment also continues to grow.

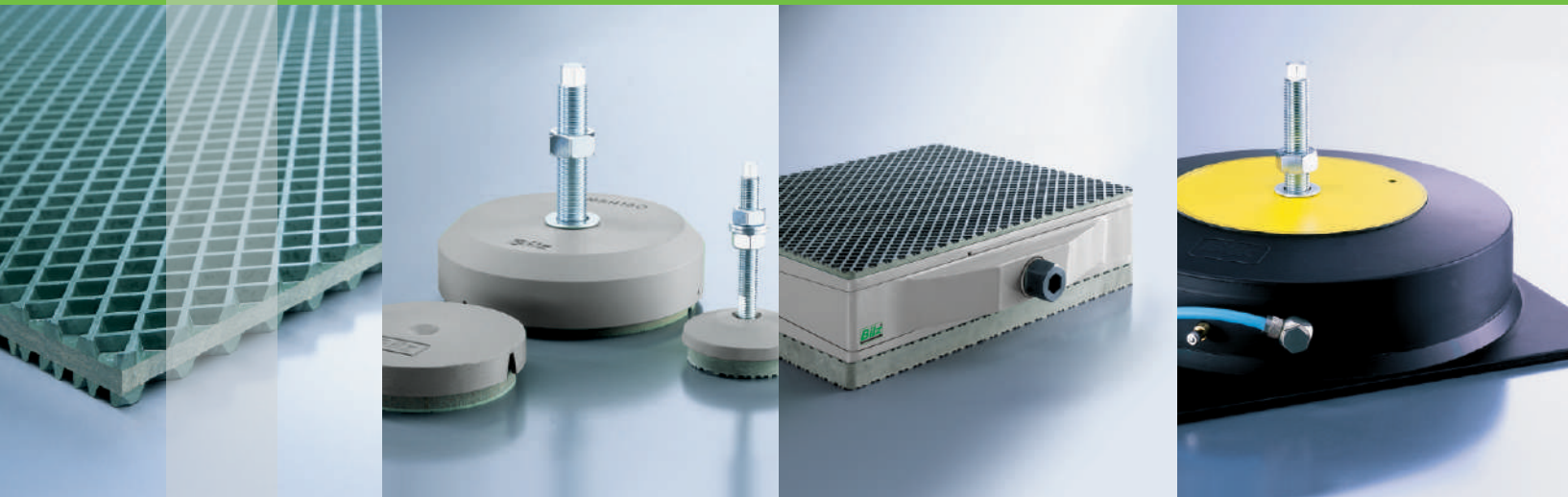

DEFINITION OF TERMS

Damping is the physical property of an insulator to remove energy of a vibrating system. This limits the vibrations to an acceptable level and converts mechanical energy into heat.

Insulation means the decoupling of disturbance forces and vibrations. This effect always works in both directions, that is from the machine to the environment as well as in the opposite direction.

Source insulation is the vibration-isolated mounting of a machine in order to reduce its pulse or sinusoidal vibration forces. This protects objects in the environment such as adjacent machines, the building and people from the disturbing forces.

The special task here is to keep the movement of the now elastically mounted machine within its operational limits.

In the case of **receiver insulation** it is necessary to protect vibration-sensitive equipment (e.g. measuring machines) from interfering ground vibrations. The production or characterization of ever smaller components, down to structures consisting of a few atoms or molecules, make heavy demands on facilities and their vibration insulation.

Passive vibration isolators exhibit upon excitation an amplification of the vibration amplitude in the range of the natural frequency. This resonance amplification is dependent on the damping characteristics of the isolators.

Active vibration isolators generate a counter-force phase-shifted by 180° through a suitable control; the isolators act as actuators. The resonance amplification in the natural frequency range of the isolators is minimized. An optimum isolating effect is achieved with frequencies above the resonance range.

Vibration control matching

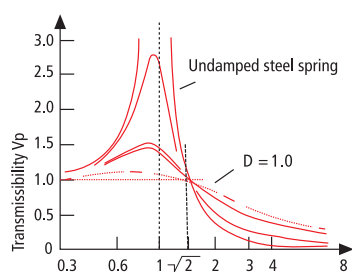

Matching ratio

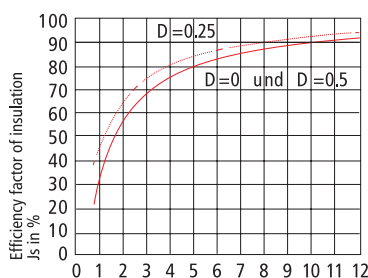

Insulation of periodically excited vibrations

The effect of vibration insulation depends mainly on the ratio of the disturbance frequency or excitation frequency to the natural frequency of the insulator (matching ratio), and its damping. With source insulation the excitation frequency is the machine speed or stroke rates, with receiver insulation disturbing ground vibrations. Generally it can be said that the lower the natural frequency of the insulator the better the efficiency of the insulator, i.e., the larger the ratio of disturbing frequency is compared to the natural frequency. The resulting graph shows that an isolating effect only occurs when the value of the harmonizing ratio is greater than $\sqrt{2}$. At smaller values an amplification (resonance magnification) of the disturbing force may also occur.

Transmission factor V_s of the vibration insulation without damping:

$$V_s = 1 - \frac{\eta^2 - 2}{\eta^2 - 1}$$

The transmission factor V_p taking into account the damping ratio D is:

$$V_p = \sqrt{\frac{1 + 4D^2\eta^2}{(1 - \eta^2)^2 + 4D^2\eta^2}}$$

f_{dist} Disturbing or exciting frequency

f_0 Natural frequency of the insulator

$\eta = \frac{f_{dist}}{f_0}$ Matching ratio

Usually a matching ratio of between 3 and 4 is striven for, whereby 3 is considered the technical lower limit and 4 the economic upper limit. A matching ratio larger than 4 cannot normally be justified from the economic perspective because the material expense would increase above average compared to the degree of insulation

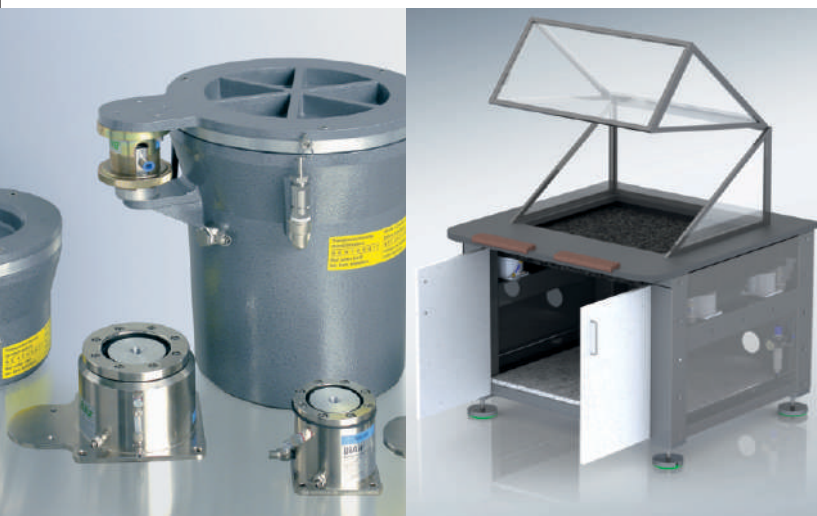

IMPACT INSULATION

Impact insulation

The physical properties of impacts are their duration, direction and magnitude. The object of impact insulation is to change the forcing frequency consisting of a high kick into an impulse of longer duration accompanied by small residual forces. Different from periodically excited vibrations, the system provided with springs vibrates in the excited natural frequency of the insulated system, not according to its number of strokes. The residual forces transferred via the insulators become increasingly smaller, the longer the natural vibration period lasts and therefore the smaller the natural frequency of the system sitting on a foundation equipped with springs.

So, the efficiency factor of an impact insulation is:

$$J_5 = 100 \times \left(1 - \frac{1}{\eta_s}\right) \% ; \quad \eta_s = \frac{\eta_b}{\eta_e}$$

η_b = natural frequency of the system rigidly secured to the ground

η_e = natural frequency of the system when placed on insulators containing springs.



Insulation pads

Bilz insulation pads have been used successfully for many years in a variety of industries as an economical solution in the fight against problems caused by vibration and structure-borne noise.

Made from a precisely defined combination of nitrile rubber and cork particles embedded in a composite of cotton fibres, the physical and mechanical properties of this high-quality composite material meet all of the current requirements for various industrial applications depending on type of pad. Very good damping properties ensure optimum deflection and level consistency both under static and under dynamic loading.

The material composition used ensures secure anti-slip protection on conventional industrial floors. It has high resistance properties particularly to modern cooling lubricants.

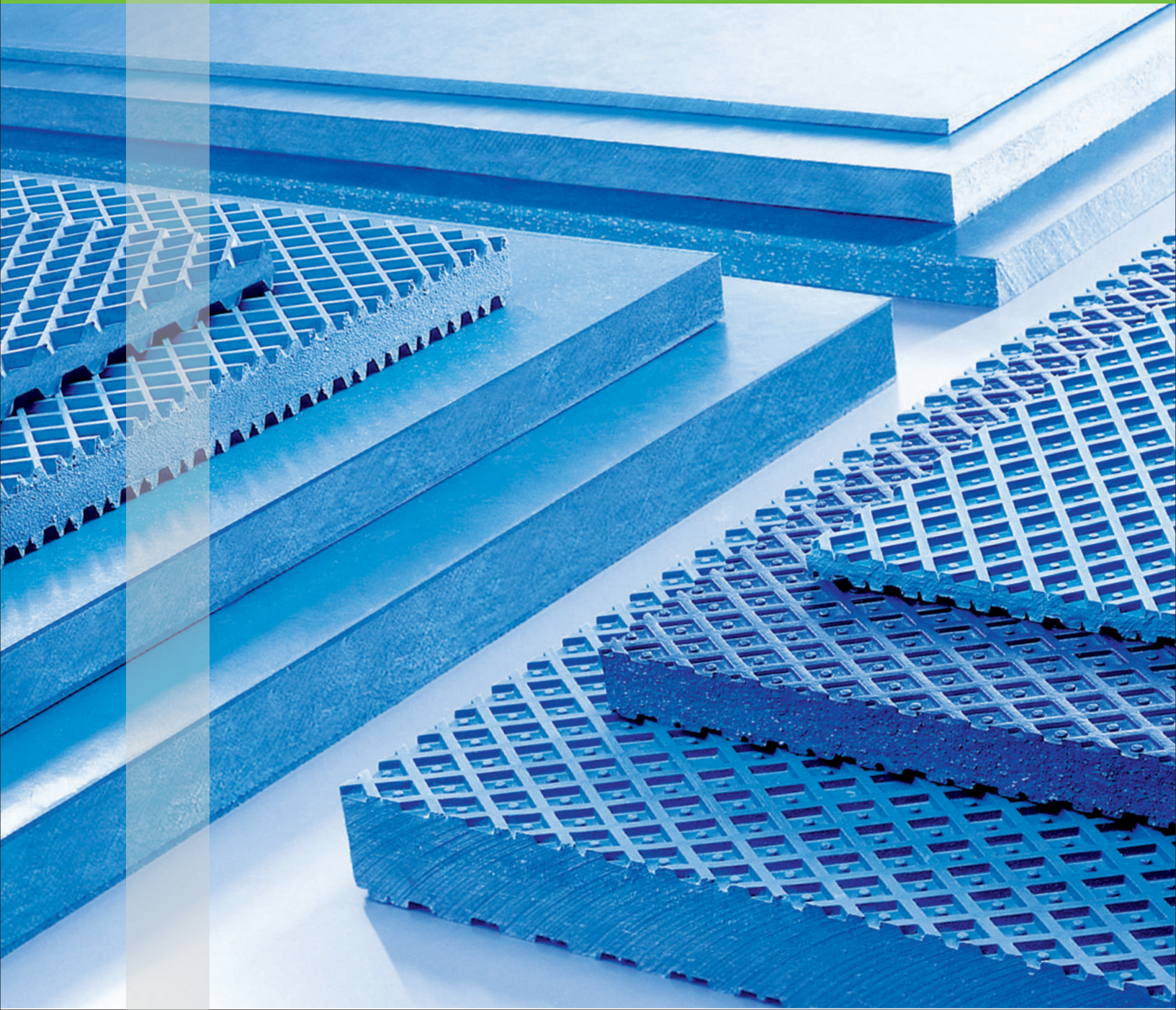

Avoiding vibration and structure-borne noise problems has always been in our focus during the development of Bilz insulating pads. As, depending on the type of machine, the requirements can be very different because of the dynamic particularities, there are numerous different types of pads available for almost any vibration problem. Especially noteworthy are the excellent compression set values of our insulation pads. This property is particularly important in vibration-isolated mounting of modern machines because the geometric accuracy must remain unchanged and stable for years.

Structure-borne noise

Effective noise insulation

Aging resistant

Virtually unlimited service life with adherence to load values. No permanent changes in shape.

Chemical resistance

Exceptionally good resistance to oils, grease, acids and cooling emulsions used in industry.

Temperature resistance

-20 °C to +120 °C

Damping properties

Very high degree of damping of up to 30 %

FOUR POSSIBLE OPTIONS FOR THE USE OF INSULATION PADS FOR MACHINE INSTALLATION

1

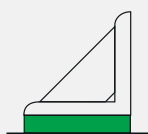

Free-standing machine foundations using Bilz insulation pads with low demands on alignment. The uneven floor is compensated for with pads, etc. The arrangement of the pads is usually a pattern of points, not over the full surface. Number and size of the required insulation pads is given by the weight of the machine and the existing support surface.

2

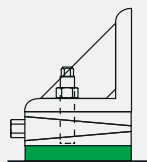

Stable connection to the machine bed using **bolt-on installation fittings** that remain in place when the machine is lifted. Specifically for machines with high dynamic forces (injection moulding machines, stamping equipment, etc.).

3

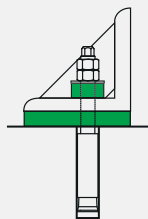

Bolt-through ground anchoring using insulation pads and insulation washers. The use of insulation washers prevents vibrations being transmitted through the bolt.

4



Highly effective shock and vibration insulation by **Bilz insulation pad sets**. Different Bilz pads are combined into pad sets offering significantly improved insulation.

Bilz insulation pads are resistant to the following substances:

Lubricants

Greases for plain and roller bearings, gear greases

Synthetic lubricants

Polyalkylene, carboxylic acid esters, antifreeze

Combustibles and fuels

Petrol, diesel fuel, heating oil, aviation fuel, special fuels

Fire resistant hydraulic fluids

Oil-in-water emulsions, water-in-oil emulsions, aqueous polymer solutions

Mineral oils

Common water-miscible cooling lubricants, ATF (Automatic Transmission Fluid), cooling lubricants, water-miscible anti corrosive oils, slideway oils, compressed air oils, lubricating oils, heat transfer oils, filter oils, rolling oils, automotive gear oils, brake fluids based on mineral oil

Cleaning agents

Hydro-chlorofluorocarbons, benzene, cold cleaner

Cleaning agent (aqueous solutions)

Washing and cleaning agents, wetting agents, dilute acids, dilute alkalis, salt solutions

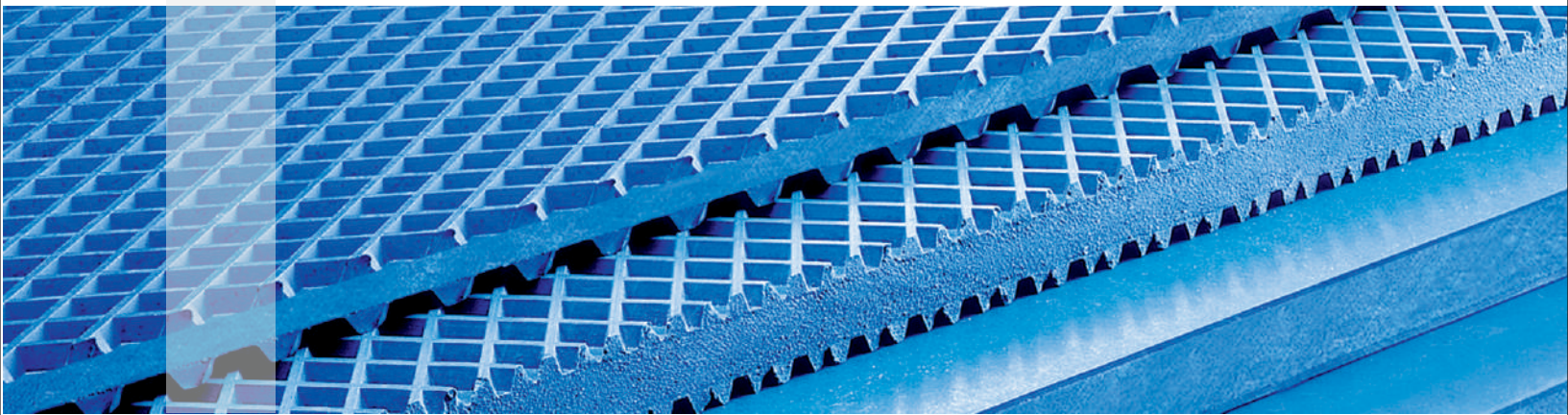

PAD TYPE B4⁽²⁾

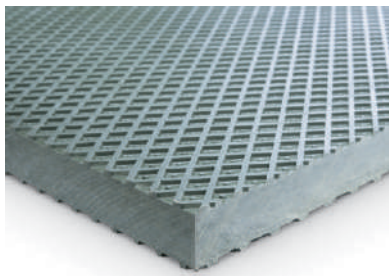

High universal variant. Can be used for machine tools, plastic machines and printing machines. Very well suited for machines with a tendency to “wander”.

Type	Load Kg/cm ²	Height mm	Coefficient of friction ⁽³⁾
B4	3-10	15	0.8

DYNAMIC NATURAL FREQUENCY

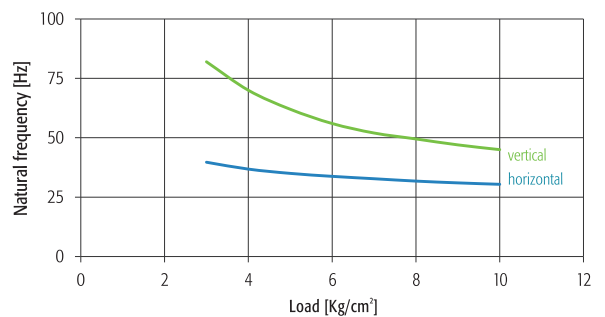

PAD TYPE B0

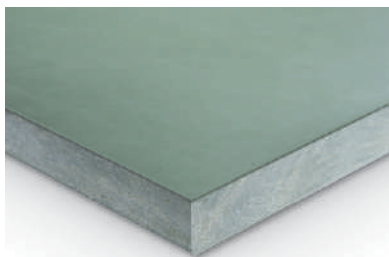

Variant without profiles. Very good level consistency. Specifically for machines with low intrinsic rigidity such as machining centres, lathes and grinding machines, etc.

Type	Load Kg/cm ²	Height mm	Coefficient of friction ⁽³⁾
B0	5-20	15	0.6

DYNAMIC NATURAL FREQUENCY

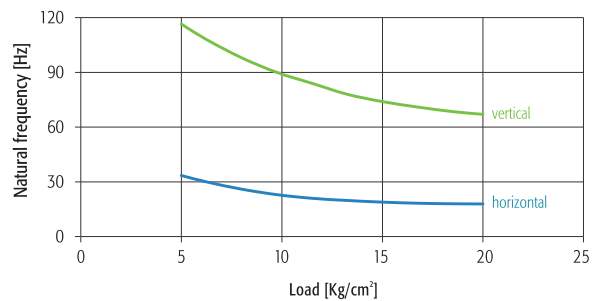

PAD TYPE B6

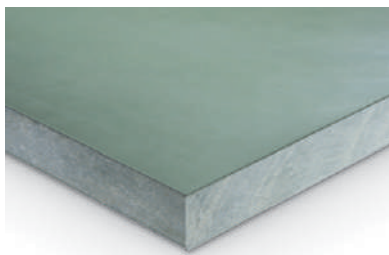

Variant without profiles. Extremely high load capacity with the highest level consistency. For very heavy and long-bed machines.

Type	Load Kg/cm ²	Height mm	Coefficient of friction ⁽³⁾
B6	5-35	15	0.6

DYNAMIC NATURAL FREQUENCY

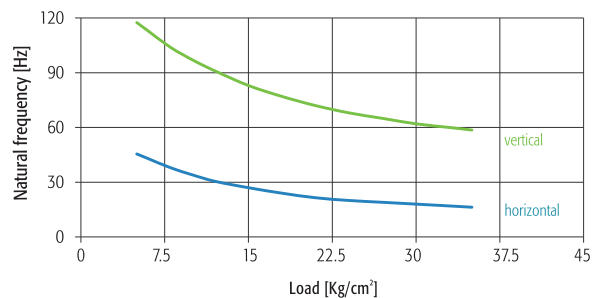

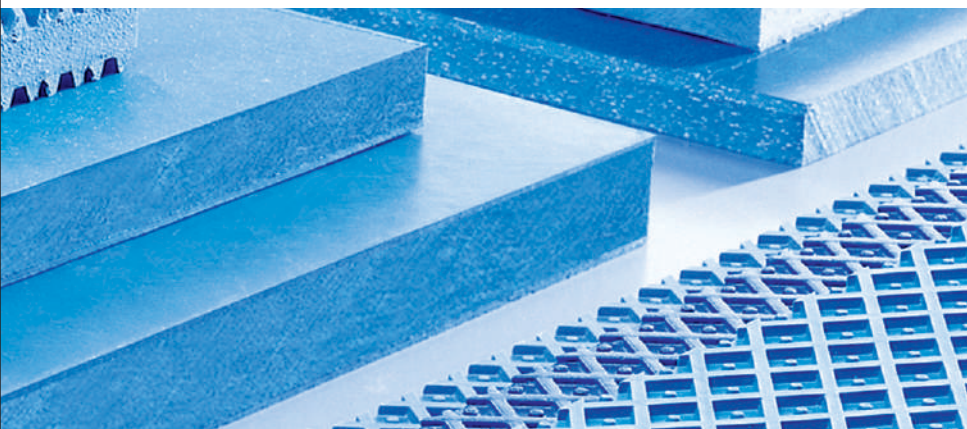

PAD TYPE B5

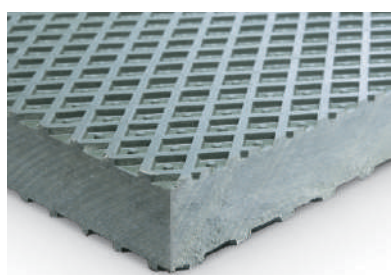

For machines subject to very highly dynamic disturbing force, such as presses, punches, shears, etc. With a profile for compensating uneven floors.

Type	Load Kg/cm ²	Height mm	Coefficient of friction ⁽³⁾
B5	5-16	25	0.8

DYNAMIC NATURAL FREQUENCY

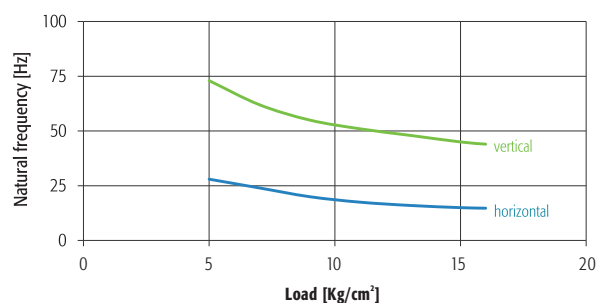

PAD TYPE B50

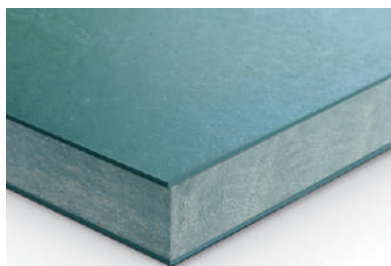

For machines subject to very highly dynamic disturbing force, such as presses, punches, shears, etc.

Type	Load Kg/cm ²	Height mm	Coefficient of friction ⁽³⁾
B50	5-20	25	0.8

DYNAMIC NATURAL FREQUENCY

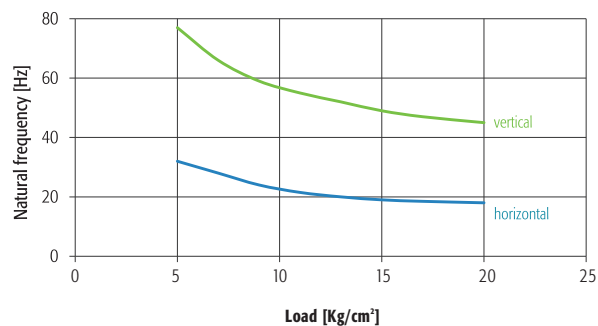

PAD TYPE B32

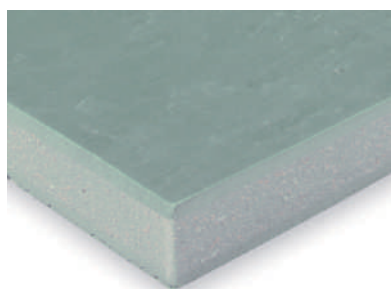

Soft variant without a profile. Excellent insulation effect for mid-sized presses, punches, etc.

Type	Load Kg/cm ²	Height mm	Coefficient of friction ⁽³⁾
B32	2-8	25	0.8

DYNAMIC NATURAL FREQUENCY

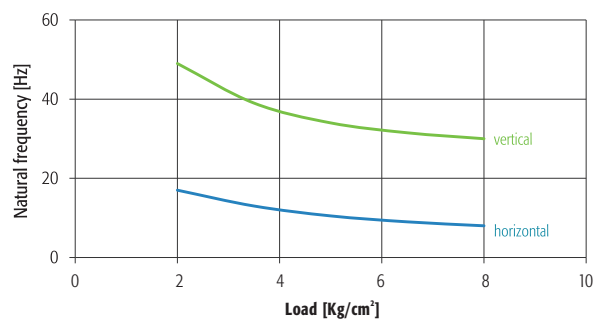

PAD TYPE B32W²⁾

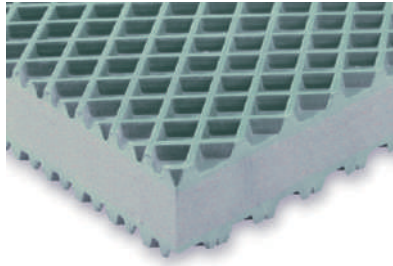

Very soft variant, comparable with B30, but with improved insulation effect.

Type	Load Kg/cm ²	Height mm	Coefficient of friction ⁽³⁾
B32W	3.5-7	25	0.8

DYNAMIC NATURAL FREQUENCY

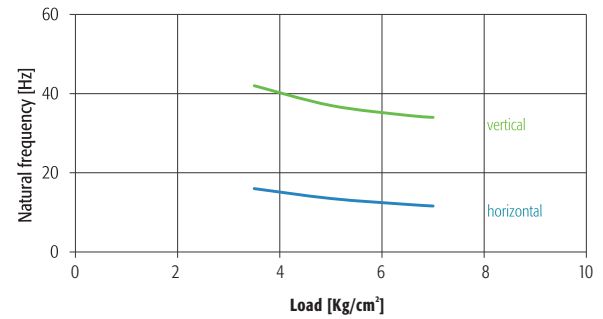

PAD TYPE B30

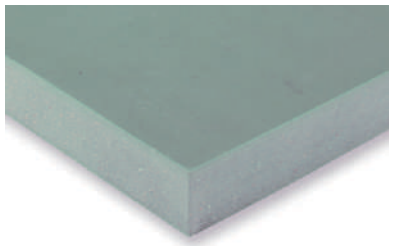

Soft variant without a profile. Particularly suitable for effective insulation when installing on upper floors.

Type	Load Kg/cm ²	Height mm	Coefficient of friction ⁽³⁾
B30	2-8	18	0.8

DYNAMIC NATURAL FREQUENCY

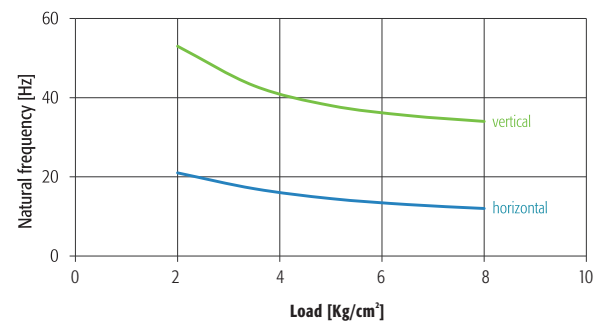

PAD TYPE B30W²⁾

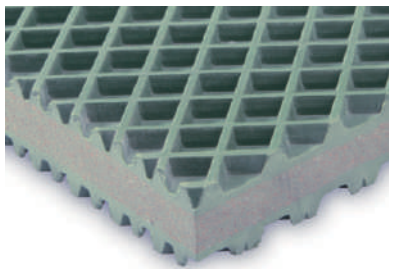

Very soft variant for optimum insulation through low-frequency matching, such as for measuring machines and inspection machines, scales and microscopes

Type	Load Kg/cm ²	Height mm	Coefficient of friction ⁽³⁾
B30W	0.5-4	18	0.8

DYNAMIC NATURAL FREQUENCY

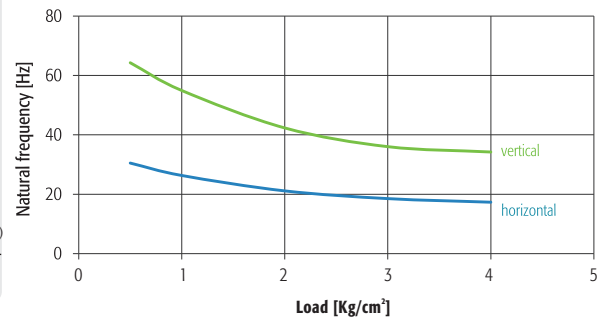

PAD TYPE B13W

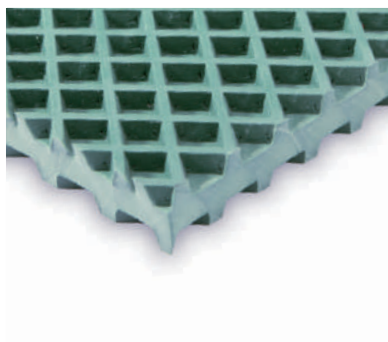

Special variant for the highest insulation values. Can be stacked up to 5 times. Matching up to approximately 8 Hz. Perfectly suited as a pad set for foundation insulation.

Type	Load Kg/cm ²	Height mm	Coefficient of friction ⁽³⁾
B13W	0.5-4	13	0.8

DYNAMIC NATURAL FREQUENCY

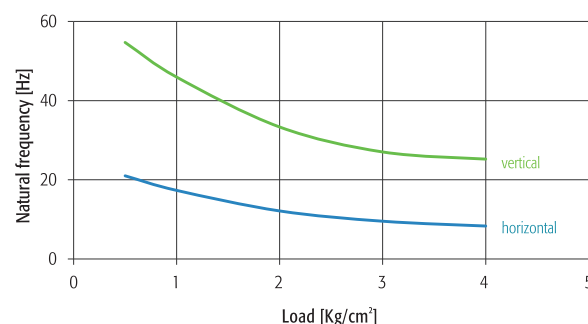

PAD TYPE BS1, BS, BN, BR7⁽²⁾

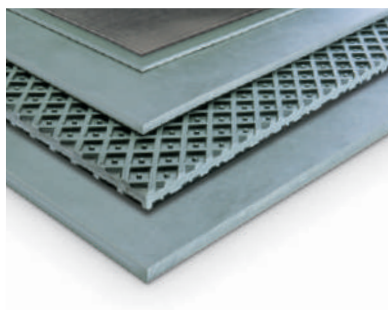

Bilz anti-slip and distance pads. No vibration insulation!

Type	Load Kg/cm ²	Height mm	Coefficient of friction ⁽³⁾
BS	1-40	2	0.9
BN	1-30	5	0.6
BR7	1-16	7	0.8

ANTI-SLIP PADS

Note

- Bilz insulation pads can be cut with any circular or band saw.
- We are happy to supply special sizes on request.
- Max square size 1000 x 500 mm and Min. size 50 x 50 mm, Max Round size Ø 300 mm and Min. Ø 50 mm.
- (1) The specified maximum load is composed of static and dynamic loading of the machine. The best insulation effect is achieved at approximately 80-90 % of the specified maximum load.
- (2) Can also be supplied with a profile on one side (designated for example B4-1).
- (3) The stated coefficient of friction refers to conventional industrial screed.
- Cutting tolerance is according to DIN 7715/T5, class P3.
- W: Waffle structure designs for compensation of uneven floors (B32W, B30W, B13W)

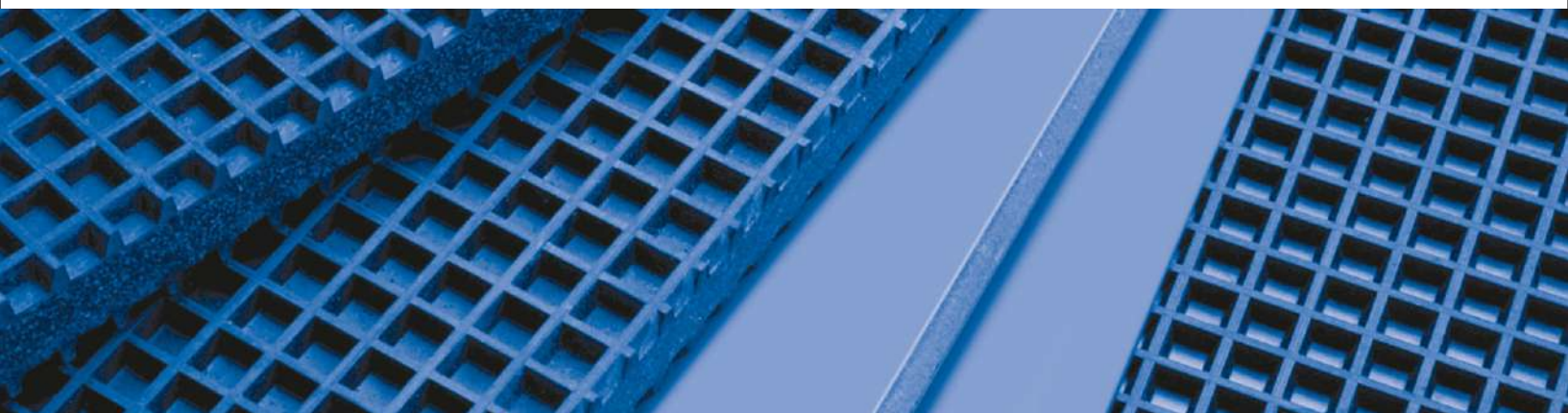

Levelling elements

Bilz levelling elements are used for vibration and structure-borne noise insulated machine installation. The maintenance-free machine feet guarantee the simple and precise levelling of machines and are available in many versatile designs. The sizes and insulation pads are selected according to the application and load. The range of levelling can be adapted depending on the selected bolt length and the individual requirements.



General information

- The type of insulation pads used can be found in the type description, e.g. BNSH 80/50 is equipped with B50, BNVS 50/30W with B30W etc.
- The specified maximum load is composed of static and dynamic loading of the machine. The best insulation effect is achieved at approximately 80-90 % of the specified maximum load.
- Details on the properties of the insulation pads used can be found on pages
- Permissible temperature range: -20 °C bis +120 °C
- Please contact us if the size, colour, insulation pad mounting, or bolts that you are looking for are not listed. In addition to our standard solutions and colours we also carry numerous special solutions. We are always happy to offer our advice.

Series BNSH/BNSHA

Round, without/with bolt-on floor attachment.

Application : Specifically developed for the mounting of injection moulding machines, presses, punches etc. Optimum load distribution due to our proven pressure plate design. Very high horizontal stability over the entire levelling range. The BNSHA elements with bolt-on floor plate are particularly suitable for all machines that tend to wander. The floor anchor is not used as a safeguard against tipping.

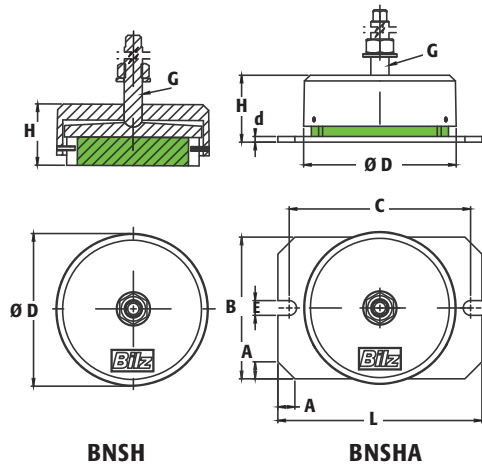

BNSH



BNSHA



BNSH / BNSHA

Type BNSH / BNSHA	Load Kg/pc	Type BNSH / BNSHA	Load Kg/pc	H BNSH With B4 and B0 mm	H BNSHA With B4 and B0 mm	Type BNSH / BNSHA	Load Kg/pc	Type BNSH / BNSHA	Load Kg/pc	H BNSH With B32 and B5 mm	H BNSHA With B32 and B5 mm	O D mm	Adjustment Range mm
70/4	300	70/0	720	25.00	29.00	70/32	275	70 / 5	500	40.00	44.00	80	6
80/4	450	80/0	940	40.00	44.00	80/32	425	80 / 5	800	44.00	48.00	96	12
100/4	700	100/0	1,470	45.00	49.00	100/32	625	100/5	1,175	49.00	53.00	113	12
120/4	1000	120/0	2,100	45.00	49.00	120/32	900	120/5	1,650	49.00	53.00	133	12
140/4	1375	140/0	2,880	45.00	49.00	140/32	1,225	140/5	2,300	49.00	53.00	153	12
160/4	1800	160/0	3,750	45.00	49.00	160/32	1,600	160/5	3,000	49.00	53.00	175	12
175/4	2150	175/0	4,500	50.00	54.00	175/32	1,900	175/5	3,600	56.00	60.00	193	12
200/4	3100	200/0	5,800	55.00	59.00	200/32	2,500	200/5	5,100	62.00	66.00	229	12
250/4	4400	250/0	9,000	55.00	59.00	250/32	3,900	250/5	7,300	64.00	68.00	270	12

BNSHA BASE PLATE DIMENSION

Type	L mm	A mm	B mm	C mm	E mm	d mm
BNSHA 70	125	15	75	105	8	5
BNSHA 80	140	15	90	120	8	5
BNSHA 100	160	15	110	140	11	5
BNSHA 120	180	15	125	160	13	5
BNSHA 140	200	15	150	180	16	5
BNSHA 160	220	15	170	200	16	5
BNSHA 175	260	20	185	230	20	8
BNSHA 200	300	20	225	270	20	8
BNSHA 250	330	20	265	300	20	8

BOLT DIMENSION

Type	Thread G	Pitch
BNSH / A 70	M10	1.25
BNSH / A 80	M12	1.50
BNSH / A 100	M16	1.50
BNSH / A 120	M16	1.50
BNSH / A 140	M16	1.50
BNSH / A 160	M20	1.50
BNSH / A 175	M20	1.50
BNSH / A 200	M24	2.00
BNSH / A 250	M30	2.00

Series BNV / BNVS

Square, without/with flexible levelling bolt

Application: Proven and very effective plate element, preferably for light to medium heavy machines with matching locating holes in the machine feet. The BNV/BNVS elements are used where a rigid joint is required between the machine and the fitting. Any unevenness or angular differences in the floor up to $\pm 3^\circ$ can be compensated for using the movable levelling bolt.

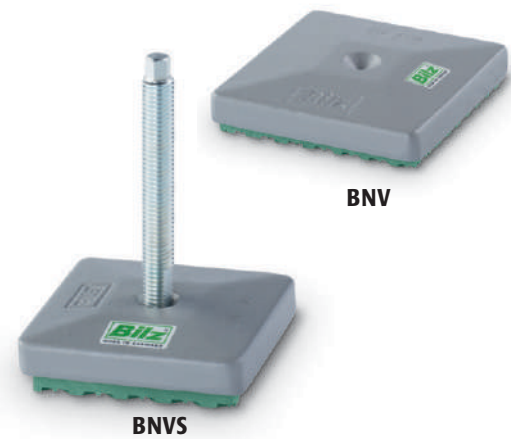

BNV / BNVS (SQUARE)

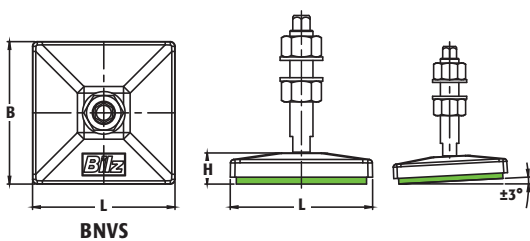

Type BNV / BNVS	Load Kg/pc	Type BNV / BNVS	Load Kg/pc	Type BNV / BNVS	Load Kg/pc	L mm	B mm	H mm With B4/B0	H mm With B30W
50/4	200	50/0	400	50/30W	95	60	60	21	24
80/4	470	80/0	950	80/30W	230	85	85	22	25
110/4	1200	110/0	2400	110/30W	500	124	124	28	31
115/4	1140	115/0	2280	115/30W	450	163	88	29	32
150/4	1800	150/0	3600	150/30W	730	147	147	30	33
200/4	3700	200/0	7400	200/30W	1500	264	165	35	38

BNR / BNRS

Round, without/with flexible levelling bolt

Application, Properties and bolts:

See type BNR/BNRS

BNR/BNRS are used in cases where a firm connection of the element to the machine is desirable. Angle difference are equalized by means of the movable leveling screw.



BNR / BNRS (ROUND)

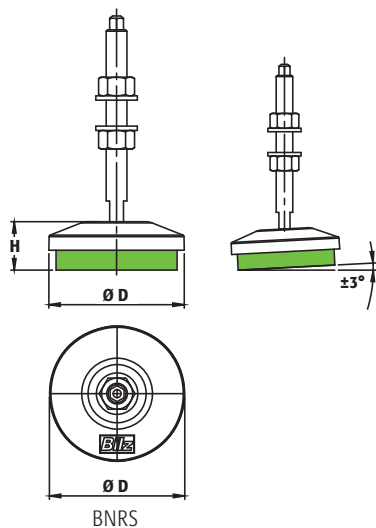

Type BNR / BNRS	Load Kg/pc	Type BNR / BNRS	Load Kg/pc	Type BNR / BNRS	Load Kg/pc	D mm	H mm With B4/B0	H mm With B30W
50/4	170	50/0	340	50/30W	60	60	21	24
65/4	300	65/0	630	65/30W	120	74	21	24
70/4	360	70/0	720	70/30W	140	85	25	28
80/4	420	80/0	840	80/30W	160	87	25	28
95/4	700	95/0	1200	95/30W	275	105	23	26
110/4	910	110/0	1820	110/30W	350	121	29	32
150/4	1700	150/0	3400	150/30W	690	163	32	35
175/4	2150	175/0	4100	175/30W	850	190	30	33
200/4	3100	200/0	6200	200/30W	1200	215	30	33
250/4	4400	250/0	8200	250/30W	1700	253	37	40

Series BNRV / BNRSV stainless-steel design

Round, stainless-steel design, without/with flexible levelling bolt

Application: Food, luxury food, packaging, chemical and pharmaceutical industries as well as clean room applications.

Insulation pad properties:

B4: Medium hard pad with good vibration and structure-borne noise insulation. Universal application.

B30W: Soft matching for a very good insulation effect, e.g. for grinding machines, test equipment, measuring machines, etc.

BR7: Anti-slip plate without vibration insulation.

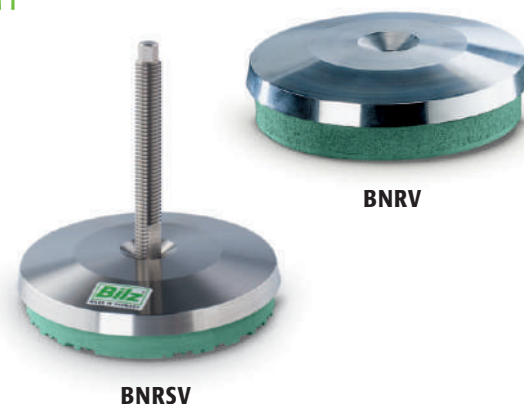

BNRV / BNRSV

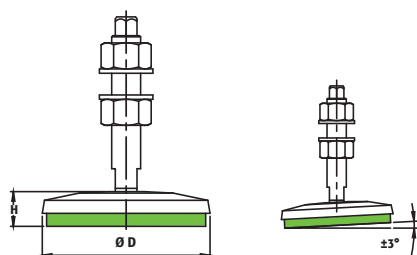

Type BNRV BNRSV	Load Kg/pc	Type BNRV BNRSV	Load Kg/pc	Type BNRV BNRSV	Load Kg/pc	D mm	H mm With B4/B0	H mm With B30W
50/4	170	50/0	340	50/30W	70	54	23	26
70/4	360	70/0	720	70/30W	140	76	25	28
110/4	910	110/0	1820	110/30W	350	116	27	30
150/4	1700	150/0	3400	150/30W	690	156	29	32

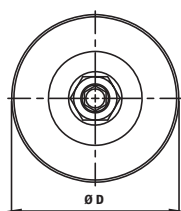

BNRSV

SERIES amt MM (round, steel with threaded rod)

Application: Cost-effective leveling mount for machines with high vertical and horizontal dynamic forces, adequate vibration and structure-borne noise isolation, pressure plate that can be precisely leveled for optimum weight distribution. The rubber mount is resistant to commercial acids, alkalis and lubricating oils.

Threaded rods: Appropriate threaded rod each with a nut and washer included.

Type	Max Load Kg/pc.	OD mm	H mm	Adjustment Range	G	Length mm
MM 1	500	80	39	+11	M12 x 1.5	110
MM 2	1,100	120	47	+15	M16 x 1.5	110
MM 3	2,100	160	54	+15	M20 x 1.5	160
MM 4	4,000	200	58	+15	M20 x 1.5	160

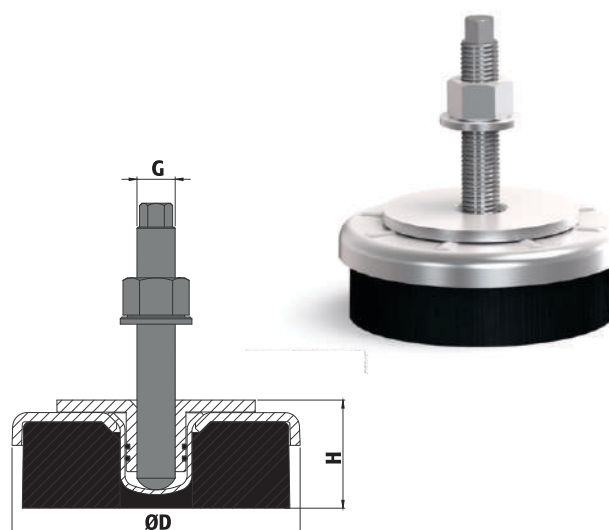

Series amt MF (Machine Fixator)

AMT Machine Fixator, Series MF

AMT MF series machine fixator is a one stop solution for precise yet cost efficient installation of heavy machinery and equipment. They are available in two basic designs: bolt-through and bolt-on. The "bolt-through" design has a clearance hole for an anchor bolt to securely anchor machines to the floor or foundation. The "bolt-on" design comes with fasteners and is designed for free-standing installations.

MF series machine fixator is based on double wedge principle. Both wedges move towards or away from the loading center symmetrically. Equalizing these forces around the center results in an absolute rigid and stable anchoring system. As there is equal load distribution through two lifting wedges, the force required to raise or lower a machine is reduced considerably, resulting in effortless and precision leveling.

Application

- Heavy machine tools for processing crankshafts and camshafts or rollers
- Boring machines, gear testing machines, horizontal and critical machining centers
- Surface grinding and laser cutting machines
- Die-casting and plastic injection molding machines
- Punching and press machines
- Turbine and compressors
- Printing machines

Advantages

- Precise and accurate machine positioning and leveling.
- Considerable reduction in machine maintenance cost.
- Machine accuracy maintained for longer duration.
- Reduced installation time thanks to effortless and precise leveling.
- No horizontal machine movement.
- No special foundation required.
- Sufficient adjustment height.



Description	UOM	Product Code		
		AMT-MF1	AMT-MF2	AMT-MF3
Max load per mount	Kg	2000	4000	5500
Permissible maximum load	Kg	12000	24000	36000
Dimensional Data				
Length x Width x Height (LxBxH)	mm	180x120x75	220x145x95	270x180x110
Height adjustment (h)	mm	5	6	7
Bolt through size (f)	mm	24	28	37
Bolt on size (M)	mm	M20	M24	M30
Adjustment screw hex head (SW)	mm	22	27	27
Resting Diameter (D)	mm	75	92	113
c	mm	32	34	43
l	mm	95	122	145
e1	mm	14	18	22
e2	mm	26	32	39

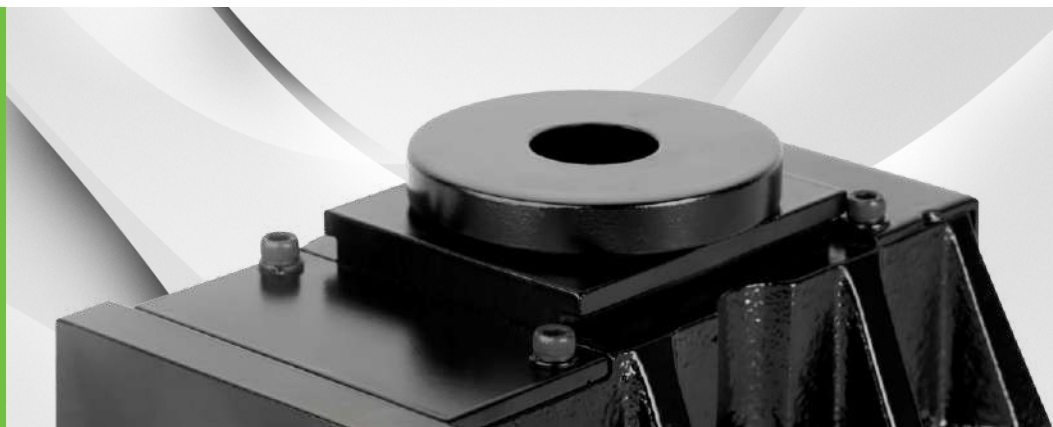
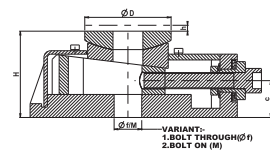
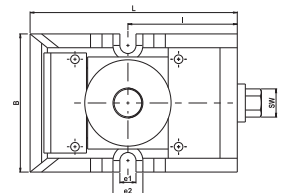

Precision levelling wedges

Due to their large contact area Bilz precision levelling wedges (PK) for vibration and structure-borne noise insulation offer optimum support and stiffening of the machine bed. They are available in a wide range of sizes and dimensions as free-standing, bolt-on to the machine or bolt-through to the foundation design.



The proven design principle enables the machine to be quickly leveled to a degree of leveling in the 1/100 mm (0.0004") range even at loads of 100 tons per wedge.

The powerful self-locking effect of the leveling bolt prevents self-loosening under the effects of vibration. Depending on the application, their use in conjunction with Bilz isolation pads creates the perfect rigidity with very effective vibration isolation.

General information

- On request we supply special solutions in terms of color, isolation pad mounting and dimension.
- Allowable temperature range: -20 °C to +120 °C (-5 to +250 °F)
- To simplify handling the upper or lower wedge can be secured with a tension spring.
- The general tolerances in accordance with ISO 2768 vL apply to the specified lengths and widths. The specified height at the center position is subject to a tolerance of ± 1 mm (± 0.04 ").

Precision levelling wedge **PK** Free-standing

Specifically for machines without mounting holes in the machine bed

Colour: RAL 7037, dusty grey

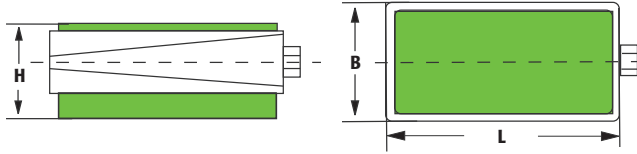

Note

- The specified maximum load is composed of static and dynamic loading of the machine. The best insulation effect is achieved at approximately 80-90 % of the specified maximum load.
- Please contact us if the size or insulation pad mounting that you are looking for is not listed. In addition to our standard solutions and colours we also carry numerous special solutions. We are always happy to give advice.

A-MOUNTING



Universal application for machine tools and injection moulding machines. Very good insulation effect. Specifically for machines subject to high horizontal forces. Very high anti-slip effect!

TOP FACE:
Anti-slip pad
BR7-1
BOTTOM FACE:
Insulation pad B4-1

B-MOUNTING

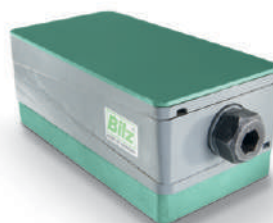

Special design for CNC lathes, grinding machines, drilling and cutting mills, cutting centres, transfer lines.

TOP FACE:
Anti-slip padBS
BOTTOM FACE:
Insulation pad B0

C-MOUNTING



Highly effective vibration insulation. Especially for installation on upper floors. Please contact us in cases of sensitive applications.

TOP FACE:
Anti-slip pad BS
BOTTOM FACE:
Insulation pad B32

D-MOUNTING



For machines with high dynamic forces such as presses, punches, shears.

TOP FACE:
Anti-slip pad
BR7-1
BOTTOM FACE:
Insulation pad B5

E-MOUNTING

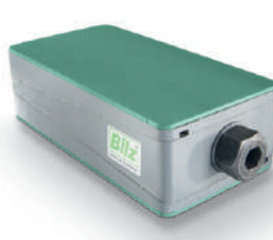

Machines and systems that require no vibration insulation. Good frictional engagement due to equipping with anti-slip plates. Very low overall height.

TOP FACE:
Anti-slip pad BS
BOTTOM FACE:
Anti-slip pad BS

F-MOUNTING



For extremely high loads. Very good level consistency.

TOP FACE:
Anti-slip pad BS
BOTTOM FACE:
Insulation pad B6



Type	Overall Dimensions		A-Mounting		B-Mounting		C-Mounting		Adjustment Range mm
	L mm	B mm	Load Kg/Pc	H Center Position mm	Load Kg/Pc	H Center Position mm	Load Kg/Pc	H Center Position mm	
PK 1	105	55	540	59	1,000	54	460	64	+4/-5
PK 2	150	75	1,000	63	2,100	58	870	68	+5/-6
PK 2.5	115	115	1,200	67	2,500	62	1,000	72	+4/-5
PK 3	200	95	1,800	67	3,600	62	1,460	72	+5/-5
PK 3/72	200	95	1,800	94	3,600	89	1,460	99	+5/-4
PK 3.2	150	150	2,000	68	4,300	63	1,700	73	+5/-6
PK 3.5	115	250	2,600	92	5,500	87	2,200	97	+4/-8
PK 3.8	170	170	2,600	76	5,500	71	2,200	81	+6/-8
PK 4	200	200	3,800	70	7,700	65	3,100	75	+5/-7
PK 4/72	200	200	3,800	94	7,700	89	3,100	99	+5/-7
PK 4.5	180	230	3,900	84	7,950	79	3,200	89	+9/-9
PK 5	200	250	4,800	94	9,700	89	3,900	99	+10/-7
PK 5.5	300	250	7,300	106	14,400	101	5,800	111	+10/-8
PK 6	250	330	8,000	94	16,100	89	6,450	99	+7/-10
PK 7	300	400	11,750	95	23,600	90	9,450	100	+8/-12
PK 8	400	500	19,550	95	39,300	90	15,700	100	+8/-14
PK 9	500	600	29,450	137	59,100	132	23,600	142	+12/-15

Type	Overall Dimensions		D-Mounting		E-Mounting		F-Mounting		Adjustment Range mm
	L mm	B mm	Load Kg/Pc	H Center Position mm	Load Kg/Pc	H Center Position mm	Load Kg/Pc	H Center Position mm	
PK 1	105	55	870	69	1,600	41	1,900	54	+4/-5
PK 2	150	75	1,700	73	3,250	45	3,800	58	+5/-6
PK 2.5	115	115	2,000	77	3,800	49	4,450	62	+4/-5
PK 3	200	95	2,900	77	5,490	49	6,400	62	+5/-5
PK 3/72	200	95	2,900	104	5,490	76	6,400	89	+5/-4
PK 3.2	150	150	3,450	78	6,500	50	7,580	63	+5/-6
PK 3.5	115	250	4,450	102	8,350	74	9,700	87	+4/-8
PK 3.8	170	170	4,450	86	8,350	58	9,700	71	+6/-8
PK 4	200	200	6,200	80	11,640	52	13,500	65	+5/-7
PK 4/72	200	200	6,200	104	11,640	76	13,500	79	+5/-7
PK 4.5	180	230	6,400	94	12,000	66	13,950	89	+9/-9
PK 5	200	250	7,700	104	14,550	76	17,000	89	+10/-7
PK 5.5	300	250	11,600	116	21,800	88	25,300	101	+10/-8
PK 6	250	330	12,900	104	24,200	76	28,200	89	+7/-10
PK 7	300	400	18,900	105	35,500	77	41,400	90	+8/-12
PK 8	400	500	31,400	105	58,950	77	68,000	90	+8/-14
PK 9	500	600	47,000	147	88,700	119	1,03,500	132	+12/-15

Precision levelling wedge series **PKA**

Bolt-on Bilz precision levelling wedges PKA are used on machines subject to high thrust that require a permanent connection to the machine bed, such as injection moulding machines, slotting machines, extrusion machines etc.

The bolt-on levelling wedges remain in position even when the machine is lifted, significantly easing the installation of the machine.

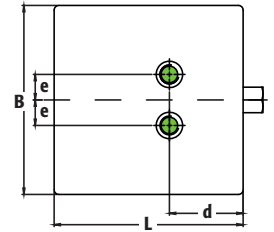
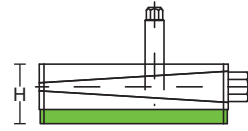

Note

- The type of Insulation pads used can be found in the type designation, for example PKA 3-0 is equipped with pad B0, PKA 3-4 with B4.
- The specified maximum load is composed of static and dynamic loading of the machine. The best insulation effect is achieved at approximately 80-90 % of the specified maximum load.
- Please contact us if the size, insulation pad mounting or bolt size that you are looking for is not listed. In addition to our standard solutions and colours we also carry numerous special solutions. We are always happy to give advice.



PRECISION WEDGE MOUNT SERIOUS PKA, BOLT - ON

Type	Size L X B	Load kg/pc	Height H in intermediate position mm	d/e mm	Inside thread mm	Range of adjustment	Range of Application
PKA 1-0	115 X 115	2,500	59	50 / 24	M 16	+3/-3	PKA 1 up to 5-0 (Insulating Plate B0) Lathes, horizontal drilling machines, surface and cylindrical grinders, CMC machining Centres.
PKA 2-0	150 X 150	4,300	61	60 / 23	M 18	+4/-4	
PKA 3-0	200 X 200	7,700	62	75 / 27	M 20	+4/-6	
PKA 4-0	200 X 250	9,700	87	95 / 27	M 20	+10/-7	
PKA 5-0	250 X 330	16,100	88	125 / 105	M 24	+6/-10	
PKA 6-0	300 X 400	23,600	88	150 / 95	M 24	+8/-12	
PKA 7-0	400 X 500	39,300	88	200 / 130	M 24	+8/-14	
PKA 8-0	500 X 600	59,100	130	255 / 150	M 30	+12/-15	
PKA 1-4	115 X 115	1,200	59	50 / 24	M 16	+3/-3	PKA 1 up to 5-4 (Insulating Plate B4) Milling and drilling machines, Printing and packing machines. Injection Moulding Machines and other plastic machines.
PKA 2-4	150 X 150	2,000	61	60 / 23	M 18	+4/-4	
PKA 3-4	200 X 200	3,500	62	75 / 27	M 20	+4/-6	
PKA 4-4	200 X 250	4,500	87	95 / 27	M 20	+10/-7	
PKA 5-4	250 X 330	7,400	88	125 / 105	M 24	+6/-10	
PKA 6-4	300 X 400	11,750	88	150 / 95	M 24	+8/-12	
PKA 7-4	400 X 500	19,550	88	200 / 130	M 24	+8/-14	
PKA 8-4	500 X 600	29,450	130	255 / 150	M 30	+12/-15	
PKA 1-32	115 X 115	900	69	50 / 24	M 16	+3/-3	PKA 1 up to 5-32 (Insulating Plate B32) Power presses, Press Braker, Shearing machine, Plastic Machines, DG Sets & Compressors.
PKA 2-32	150 X 150	1,500	71	60 / 23	M 18	+4/-4	
PKA 3-32	200 X 200	2,800	72	75 / 27	M 20	+4/-6	
PKA 4-32	200 X 250	3,500	97	95 / 27	M 20	+10/-7	
PKA 5-32	250 X 330	5,800	98	125 / 105	M 24	+6/-10	
PKA 6-32	300 X 400	9,450	98	150 / 95	M 24	+8/-12	
PKA 7-32	400 X 500	15,700	98	200 / 130	M 24	+8/-14	
PKA 8-32	500 X 600	23,600	140	255 / 150	M 30	+12/-15	

Plastic injection moulding machines, die casting machines, planing and slotting machines, cold extrusion machines, etc. Extreme slip resistance.

TOP FACE:
Plain surface
BOTTOM FACE:
Insulation pad B4



Precision levelling wedge series PKD

Bolt-through Bilz precision levelling wedge PKD are used on machines that necessarily need to be anchored due to unfavourable centre of gravity proportions. Also for machines that must be pushed or pulled when levelling – and for machines with low intrinsic rigidity.

Bolts: Not supplied as a standard scope can be supplied on request

Note

- The type of insulation pads used can be found in the type designation, for example PKD 3-0 is equipped with pad B0, PKD 3-4 with B4.
- The specified maximum load is composed of static and dynamic loading of the machine. The best insulation effect is achieved at approximately 80-90 % of the specified maximum load.
- Please contact us if the size, insulation pad mounting or bolt size that you are looking for is not listed. In addition to our standard solutions and colours we also carry numerous special solutions. We are always happy to give advice.

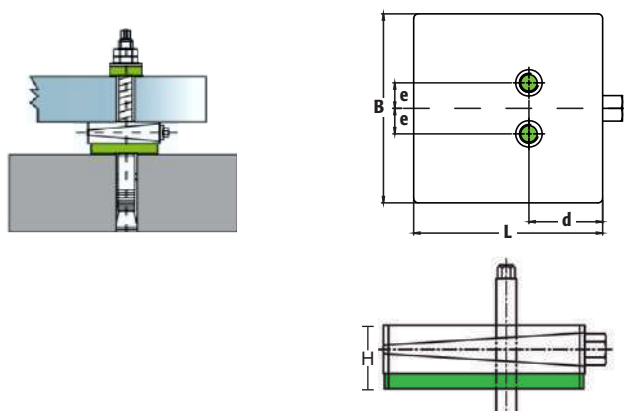

PKD 1-0 TO PKD 8-0

Boring and cutting mills, machining centres, special machines, long bed lathers, long bed planing machines.

TOP FACE:
Plain surface
BOTTOM FACE:
Insulation pad B0

Type	max. load Kg/pc.	L mm	B mm	H Centre position mm	d mm	e mm	Drill hole	Adjustment range mm
PKD 1-0	2,500	115	115	60	50	24	22	+4/-5
PKD 2-0	4,300	150	150	61	58	23	23	+5/-6
PKD 3-0	7,700	200	200	63	76	27	26	+3/-7
PKD 3/72-0	7,700	200	200	87	76	27	26	+4/-7
PKD 4-0	9,700	200	250	87	95	27	26	+10/-7
PKD 5-0	16,100	250	330	87	125	105	30	+6/-10
PKD 6-0	23,600	300	400	88	150	95	30	+8/-12
PKD 7-0	39,300	400	500	88	200	130	35	+8/-14
PKD 8-0	59,100	500	600	130	255	150	35	+12/-15



Precision levelling wedge with spherical seat Series **PKAK/PKDK**

Bilz precision levelling wedge PKAK (**bolt-on**)/ PKDK (**bolt-through**) with spherical seat to compensate for angle differences between machines and foundations, e.g. non processed machine mounts or uneven floors. Specifically for machines with a long bed and higher demands on geometry.

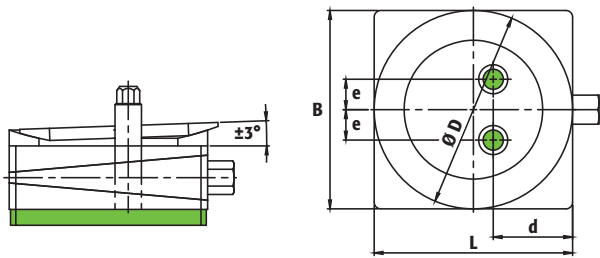

Note

- The type of insulation pads used can be found in the type designation, for example PKDK 3-0 is equipped with B0, PKDK 3-4 with B4.
- The specified maximum load is composed of static and dynamic loading of the machine. The best insulation effect is achieved at approximately 80-90 % of the specified maximum load.
- Please contact us if the size, insulation pad mounting or bolt size that you are looking for is not listed. In addition to our standard solutions and colours we also carry numerous special solutions. We are always happy to give advice.

PKAK / PKDK 1-0 TO PKAK / PKDK 4-0 WITH SPHERICAL SEAT

Type	max. load Kg/pc	L mm	B mm	H Centre position mm	O/D mm	d mm	e mm	Internal Thread	Adjustment range mm
PKAK 1-0	25,00	115	115	70	110	50	24	M16	+3/-3
PKAK 2-0	43,00	150	150	77	150	58	23	M18	+4/-4
PKAK 3-0	77,00	200	200	79	150	76	27	M20	+4/-6
PKAK 4-0	97,00	200	250	103	150	95	27	M20	+10/-7
								Drill Hole mm	
PKDK 1-0	25,00	115	115	70	110	50	24	22	+4/-5
PKDK 2-0	43,00	150	150	77	150	58	23	23	+5/-6
PKDK 3-0	77,00	200	200	79	150	76	26	26	+3/-7
PKDK 4-0	97,00	200	250	103	150	95	27	26	+10/-7

TOP FACE SPHERICAL SEAT: Painted
BOTTOM FACE: Insulation pad B0

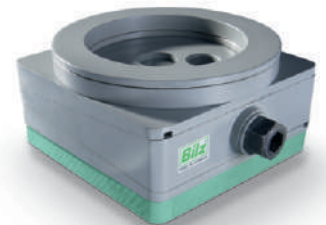

Accessories

INSULATION WASHERS TO INSULATE THE BOLT HEAD

Our insulation washers for bolt heads offer adequate vibration and structure borne noise insulation in rigidly anchored machines and components.

They can be used at temperatures between -20 and +120 °C and are distinguished by their high resistance to oils, greases, acids and coolants used in industry.

Structure borne noise insulation in rigidly anchored machines and pipe suspensions.

for bolts	outer Ø	inner Ø	Installation height	max. preload force	max. tightening torque
Ø	mm	mm	mm	kg	Nm
to M12	35	13	20	79	5
to M20	50	21	22	150	16
to M30	70	31	25	290	45



HORIZONTAL ELEMENTS

Type	max. load	a	b	c	d	e	f	g	i
	Kg/pc.	mm	mm	mm	mm	mm	mm	mm	mm
Size 1	1,650	140	125	45	60-115	50	25	35	17.5
Size 2	1,650	160	180	55	60-140	48	43	37	22

Size 1
Steel angle,
Levelling element
Type BNVS 115/5,
3 bolts
M16 x 150,
2 anchors M16

Size 2
Steel angle,
Levelling element
Type BNVS 115/5,
4 bolts
M20 x 150,
3 anchors M20

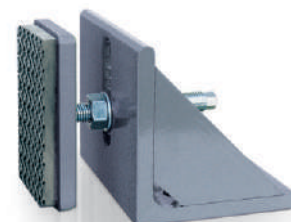

Size 1

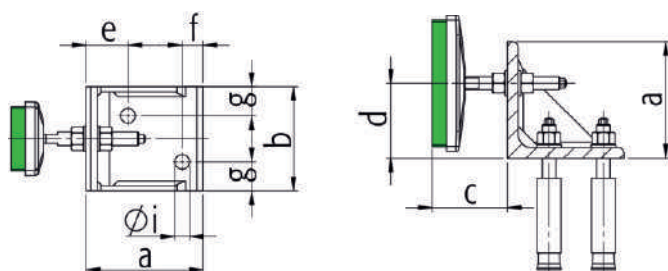

Size 2

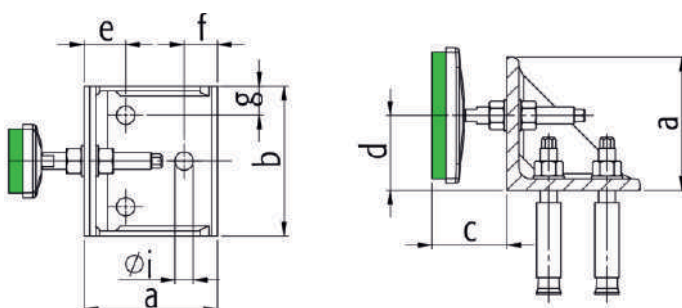

Right to make technical changes is reserved.

FAEBI®

Rubber air spring insulator

Highly effective insulation of vibrations, shocks and structure borne noise for machines, apparatus and aggregates.





FAEBI® RUBBER AIR SPRING INSULATOR

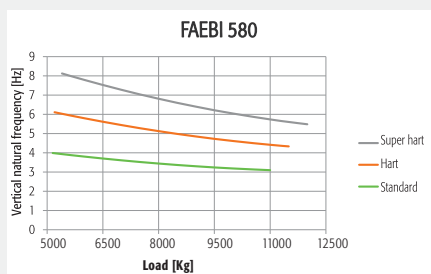
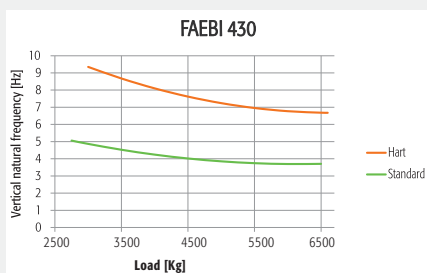
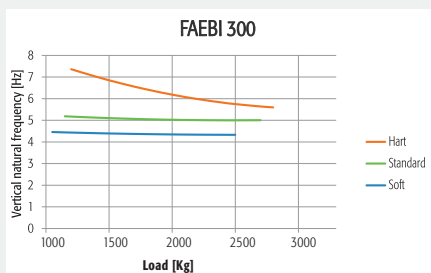
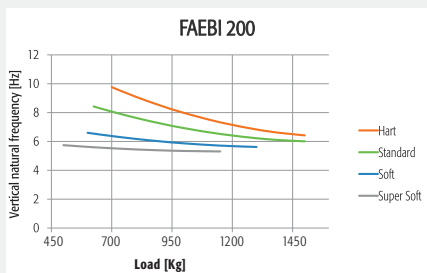
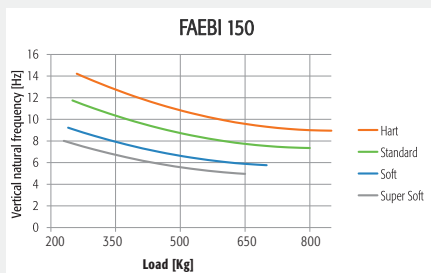
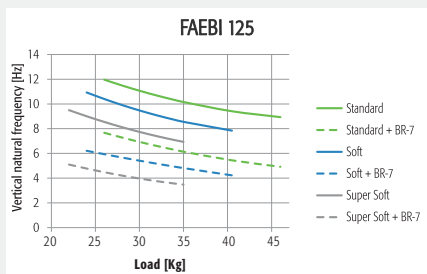
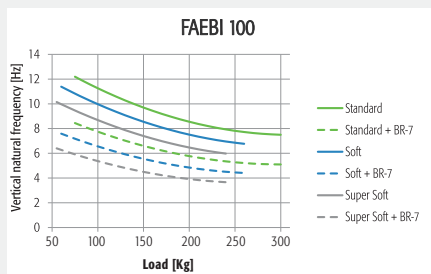
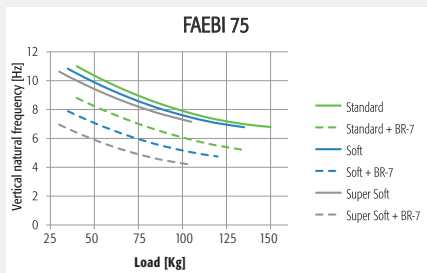
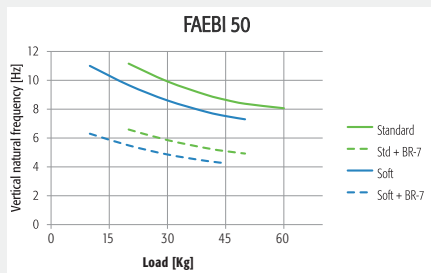

FAEBI® rubber air springs are used for the highly effective insulation of machines, apparatus and aggregates from shocks, vibrations and structure borne noise. The element comprises of a bell-shaped rubber form made from high-grade elastomer with a reinforced side wall. The constructive design does not only achieve excellent insulation properties, but also very high mechanical stability. Damage due to over-load or a sudden pressure drop is virtually impossible. The air spring element has a very low degree of deflection in the horizontal direction. The inclusion of anti-slip pads on the spring element base plate means that additional floor anchoring is not usually required.

Note:

- FAEBI® elements can also be supplied in stainless steel designs and from EDPM elastomer for outdoor use (such as air conditioning).
- To reduce the movement amplitude in the vertical direction the FAEBI® HD variant is supplied with additional damping.

Applications

Perfectly suited for source insulation of fast running presses, forging hammers and other machines and aggregates with highly dynamic disturbance forces. Passive insulation of measuring and test equipment as well as highly accurate machine tools. Can also be combined with mechanical level control on request.

SHOCK AND VIBRATION INSULATION

The natural frequency of the rubber air spring in the vertical direction is between 3 and 14 Hz depending on the allowable static load and variant. The maximum spring deflection in response to a pulse load is up to 15mm depending on the type and size of the air spring.

Right to make technical changes is reserved.

SERIES TYPE FAEBI

Type	Variant	Load Kg/pc.	max. Pressure bar	A mm	ØD mm	H approx. mm = Working height	H (deflated) mm	Ød mm	h mm	G mm
FAEBI® 50	Standard	20–60	3	110	80	60	61	35	5	M10
	Standard + BR7-1	20–50	2.5	110	80	62	68	35	5	M10
	Soft	10–50	2.5	110	80	60	61	35	5	M10
	Soft + BR7-1	10–45	2.3	110	80	62	68	35	5	M10
FAEBI® 75	Standard	40–150	3	115	97	63	67	43	5	M12
	Standard + BR7-1	40–135	2.7	115	97	65	74	43	5	M12
	Soft	35–130	2.6	115	97	63	67	43	5	M12
	Soft + BR7-1	35–120	2.4	115	97	65	74	43	5	M12
	Super Soft	30–105	2.1	115	97	63	67	43	5	M12
FAEBI® 100	Standard	75–300	5	135	118	62	65	60	5	M12
	Standard + BR7-1	75–300	5	135	118	64	72	60	5	M12
	Soft	60–260	4.4	135	118	62	65	60	5	M12
	Soft + BR7-1	60–260	4.4	135	118	64	72	60	5	M12
	Super Soft	55–240	4	135	118	62	65	60	5	M12
	Super Soft + BR7-1	55–240	4	135	118	64	72	60	5	M12
FAEBI® 125	Standard	260–460	5.5	165	140	93	98	66	5	M16
	Standard + BR7-1	260–460	5.5	165	140	95	105	66	5	M16
	Soft	240–405	4.9	165	140	93	98	66	5	M16
	Soft + BR7-1	240–405	4.9	165	140	95	105	66	5	M16
	Super Soft	220–350	4.2	165	140	93	98	66	5	M16
	Super Soft + BR7-1	220–350	4.2	165	140	95	105	66	5	M16
FAEBI® 150	Hart	260–850	6.4	200	170	91	96	80	8	M16
	Standard	250–800	6	200	170	91	96	80	8	M16
	Soft	240–700	5.3	200	170	91	96	80	8	M16
FAEBI® 200	Super Soft	230–650	4.9	200	170	91	96	80	8	M16
	Hart	700–1,500	6	260	236	91	95	130	8	M16
	Standard	625–1,500	6	260	236	91	95	130	8	M16
	Soft	600–1,300	5.2	260	236	91	95	130	8	M16
FAEBI® 300	Super Soft	550–1,150	4.6	260	236	91	95	130	8	M16
	Hart	1,200–2,800	6.5	370	340	89	93	200	8	M20
	Standard	1,150–2,700	6	370	340	89	93	200	8	M20
	Soft	1,050–2,500	5.6	370	340	89	93	200	8	M20
FAEBI® 430	Hart	3,000–6,600	6.1	500	480	89	94	315	12	M20
	Standard	2,750–6,500	6	500	480	89	94	315	12	M20
FAEBI® 580	Super Hart	5,400–12,000	6.6	680	650	89	91	380	14	M24
	Hart	5,200–11,500	6.3	680	650	89	91	380	14	M24
	Standard	5,150–11,000	6	680	650	89	91	380	14	M24

Note

- Ensure that the element is selected so that the maximum load (static and dynamic load) is not exceeded!
For applications with higher dynamics harder variants of the FAEBI® reduce the deflection of the element. However, the softer the element is, the better the achievable insulation effect is.
Please contact us, we are happy to assist with selecting a suitable element.
- If the bottom edge of the machine does not completely cover ØD, we recommend the use of our special **protective cover**
- Permissible temperature range: -20 °C to +80 °C
- The elements are attached to the holes provided on the machine using the bolts supplied (see Accessories).
Anchoring to the floor is usually not necessary.
- **Bolt in the bolt by hand only, do not use a wrench. Also only tighten the nut with low torque.**
- The machine is placed on the deflated element, which is then inflated in stages using the standard valve until dimension H (= working height) is reached. The maximum specified air pressure must also not be exceeded!
- **Inflation and deflation may only take place under load (observe the maximum permissible pressure).**
- Up to +/- 5 mm are available for levelling.

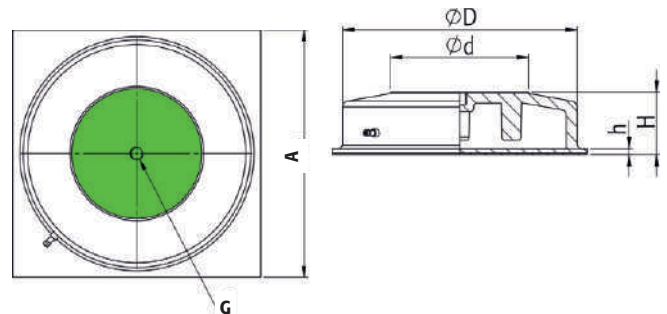

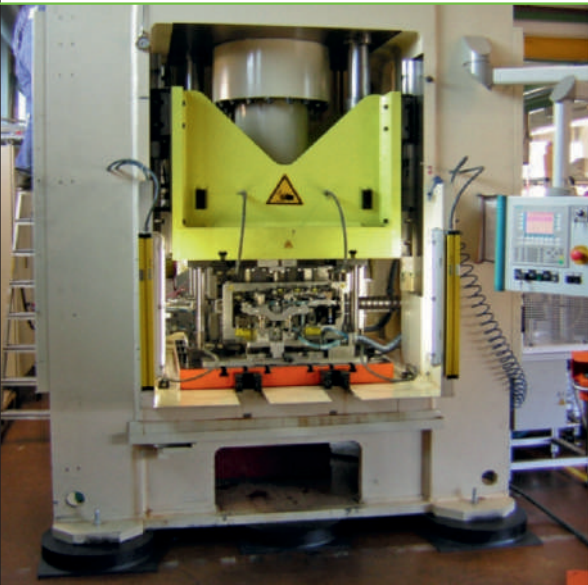

ADVANTAGES COMPARED TO STEEL SPRINGS

In comparison to steel springs the use of air spring offers many advantages when used for vibration insulation:

- Flexible insulation system design:
Changes in the static or dynamic loads can be compensated for by adjusting the air pressure. This can be performed either manually or pneumatically (e.g. using Bilz level control)
- Integrated damping, therefore separate damping is not necessary.
- No transmission of structure borne noise

PROTECTIVE COVER FOR FAEBI® AND FAEBI®-HD ELEMENTS

If the surface of the FAEBI® element (see Type series FAEBI® or FAEBI®-HD) is not completely covered by the bottom edge of the machine, then an appropriate hood is required to ensure the sufficient load distribution across the air spring. A hood will also provide protection from external damage.

Material: Steel sheet (primed black)
The protective cover is also available in stainless steel on request.

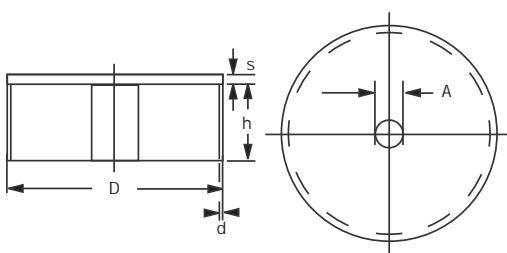
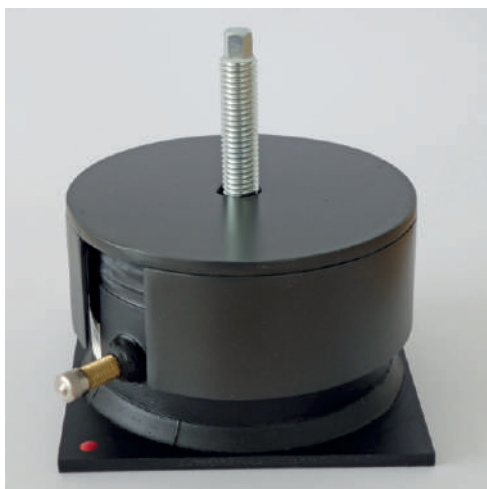

Type	A (mm)	D (mm)	s (mm)	h (mm)	d (mm)
AH- FAEBI® 50/75	13	115	5	40	2
AH- FAEBI® 100	14	140	5	45	2
AH- FAEBI® 125	18	160	5	60	2
AH- FAEBI® 150	18	190	5	60	2
AH- FAEBI® 200/-HD	18	255	5	60	3
AH- FAEBI® 300/-HD	22	360	5	60	3
AH- FAEBI® 430/-HD	22	500	10	60	4
AH- FAEBI® 580/-HD	27	680	10	60	4



Type series **FAEBI® -HD** with adjustable damping

The combined rubber-air spring insulator FAEBI® -HD with adjustable damping comprises of an elastomer metal bonding with reinforced side wall and a two-chamber system. To achieve the greatest possible damping effect the interior of the air spring is divided into two air chambers connected by an air hose (load and damping volume). An adjustable throttle valve is used to set the flow cross section to the desired damping effect from the outside. The significantly higher damping effect compared to a single chamber system (FAEBI®) reduces the resonance amplification substantially and the machine movements fade noticeably faster. The increased energy substantially absorption also has a positive effect on the manufactured goods and on machine and tool wear.

Benefits:

In comparison to viscous damping air damping is absolutely free of wear and maintenance-free and the damping factor can be easily adjusted from outside.

Note

- Ensure that the element is selected so that the maximum load (static and dynamic load) is not exceeded! For applications with higher dynamics harder variants of the FAEBI® reduce the deflection of the element. However, the softer the element is, the better the achievable insulation effect is. Please contact us, we are happy to assist with selecting a suitable element.
- If the bottom edge of the machine does not completely cover $\varnothing D$, we recommend the use of our special **protective cover**
- Permissible temperature range: -20 °C to $+80\text{ °C}$
- The elements are attached to the holes provided on the machine using the bolts supplied Anchoring to the floor is usually not necessary.
- **Bolt in the bolt by hand only, do not use an open-end wrench. Also only tighten the nut with low torque.**
- The machine is placed on the deflated element, which is then inflated in stages using the standard valve until dimension H (= working height) is reached. The maximum specified air pressure must also not be exceeded!
- **Inflation and deflation may only take place under load, observe the maximum permissible pressure.**
- Up to $\pm 5\text{ mm}$ are available for levelling.

SETTLING BEHAVIOUR FAEBI

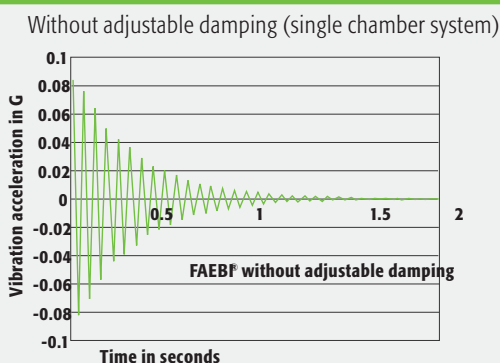

SETTLING BEHAVIOUR FAEBI-HD

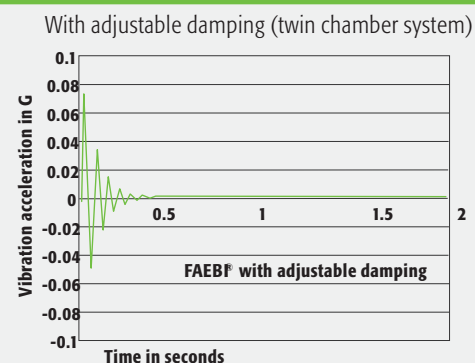

FAEBI® -HD

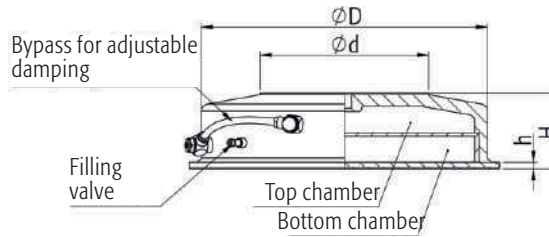
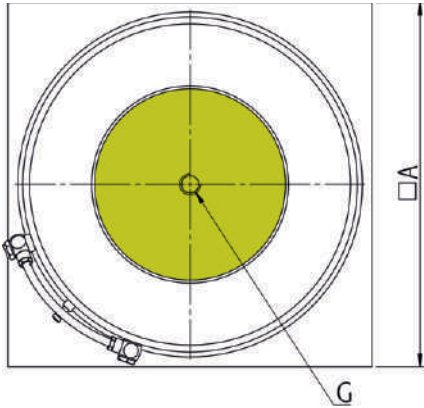

Type	Variant	Load Kg/pc	max.Pressure bar	A mm	Ø D mm	H approx. mm = Working height	H (deflated) mm	Ø d mm	h mm	G mm
FAEBI® 200-HD	Hart	700–1,500	6	260	236	89	90	130	8	M16
	Standard	625–1,500	6	260	236	89	90	130	8	M16
FAEBI® 300-HD	Hart	1,400–2,950	6.5	370	340	89	94	200	8	M20
	Standard	1,150–2,700	6	370	340	89	93	200	8	M20
FAEBI® 430-HD	Hart	3,000–6,600	6.1	500	480	91	97	315	12	M20
	Standard	2,750–6,500	6	500	480	91	96	315	12	M20
FAEBI® 580-HD	Super Hart	6,000–11,500	6.9	680	650	126	135	380	14	M24
	Hart	5,600–10,800	6.5	680	650	126	133	380	14	M24
	Standard	4,700–10,000	6	680	650	126	130	380	14	M24



NATURAL FREQUENCIES FAEBI 200-HD TO 580-HD

FAEBI® 200-HD

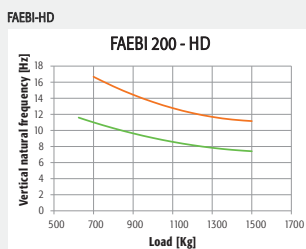

FAEBI® 300-HD

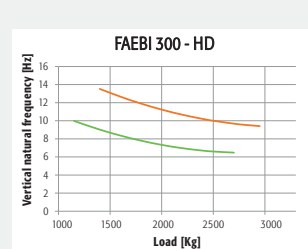

FAEBI® 430-HD

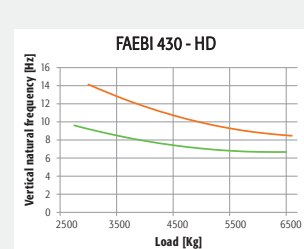

FAEBI® 580-HD

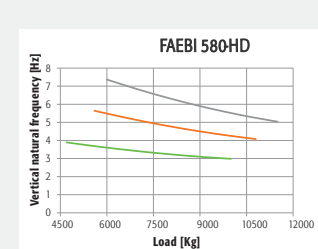

— Super Hart — Hart — Standard

Right to make technical changes is reserved.

FAEBI® AND FAEBI® -HD with mechanical-pneumatic level control (MPN-LCV)



The mechanical-pneumatic level control (MPN) with our robust proportional valve LVC represents a simple but effective solution for preventing skew positions resulting from load changes. A plunger continuously probes the level and the position of the plunger is transmitted to a slide valve. The air spring is either pressurized or the internal pressure is vented in accordance with the position of the plunger. The adjustable target level is maintained within an accuracy of $\pm 1/10$ mm. In principle three control valves are used, that optionally have an upstream air maintenance unit for conditioning the pneumatic air supply, limiting the system pressure to 6 bar, removing accumulated condensate and filtering out solid particles (rust and dust).

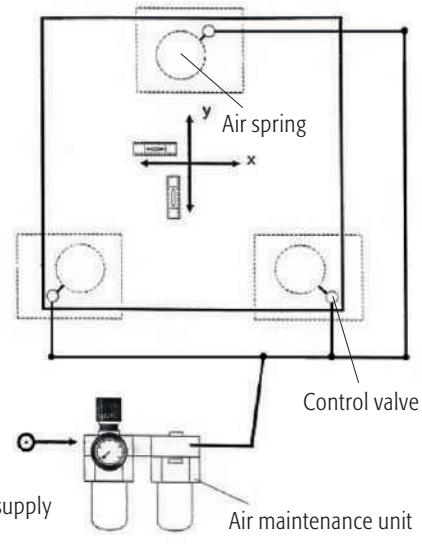

Compressed air supply
(max. 10 bar)

Air maintenance unit



BiAir®

Membrane air spring insulator

Low-frequency Bilz BiAir® membrane air spring with precisely adjustable damping for effective vibration insulation of sensitive measurement and testing equipment, precise finishing machines, laser equipment and optical and electronic instruments as well as vehicle, engine and gearbox test beds, etc.



BiAir® MEMBRANE AIR SPRING INSULATOR WITH ADJUSTABLE DAMPING

The BiAir® membrane air spring insulator is made of turned or cast aluminium. The air space is enclosed by a thin-walled flexible and pressure-resistant rolling membrane. A piston sits on top of the membrane and is pressed into the air space.

This design allows a highly-effective insulation against vibration. In order to simultaneously achieve a high degree of damping, the air space within the insulator is divided into two chambers connected with an air tube (load/damping volume). An adjustable throttle valve is used to set the flow cross section to the desired damping effect from the outside. The friction in the air flow generated by the throttle valve can create a damping effect of up to 15 %.

Damage to the rolling membrane due to overpressure is virtually excluded through the use of additional safety valves or a mechanical piston stroke limit.

- Highly effective vibration insulation of
 - sensitive measurement and testing equipment,
 - precise finishing machines,
 - laser equipment as well as optical and electronic instruments.
- Vibration insulated bearings for vehicle, engine and gearbox test beds
- Foundation insulation

Advantages compared to conventional steel springs

The use of Bilz BiAir® air spring insulators with active level control constantly maintains the correct level of machines or foundations. The level control and adjustment is completely automatic!

The pressure in the air springs is appropriately adjusted by in- or deflating in response to load changes. This keeps the insulating effect constant in every case.

Unlike steel springs air springs do not transmit structure-borne sound.



With/without insulation

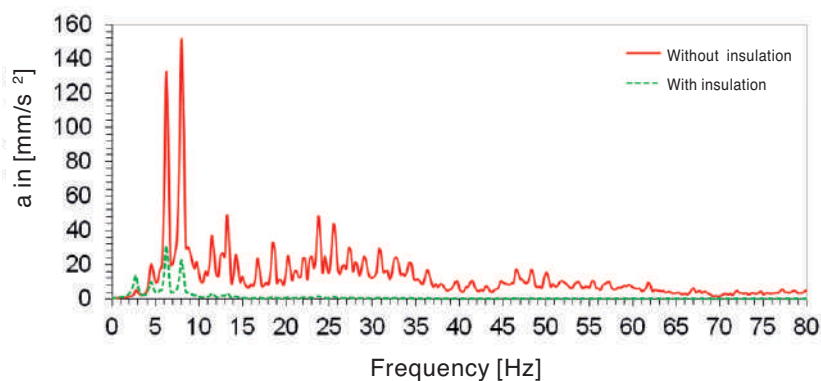

CMM Mounted on BiAir

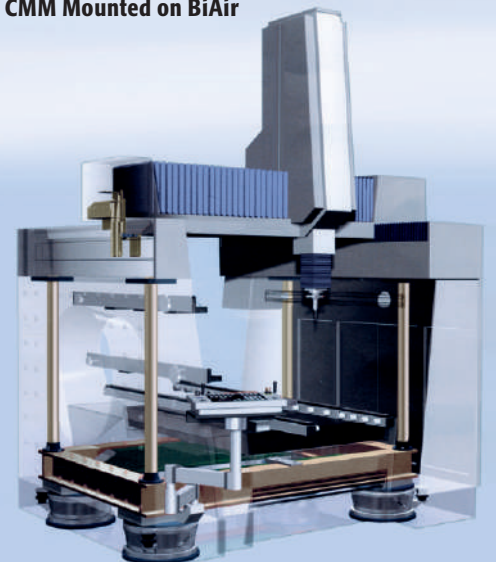

Note:

- BiAir® membrane air springs are available in the following materials depending on size
 - BiAir®-ED: Cast aluminium, powder coated RAL similar to 7037 dusty grey
 - BiAir®-ED-AL: Aluminium (naturally anodized)
- with a nose for mounting valves (MPN) or displacement sensors are available with the hose connection on the left (NL) or on the right (NR).

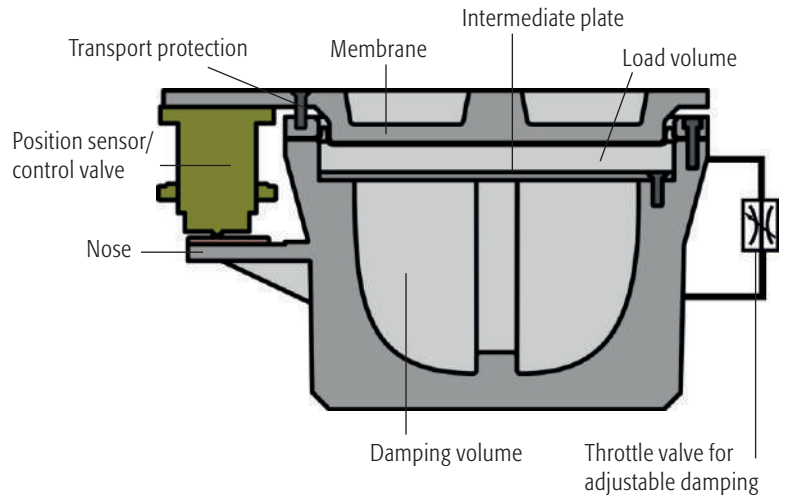

TYPE SERIES BiAir® -ED-AL IN ANODISED ALUMINIUM

Natural frequency vertical approximately 2.5 Hz, horizontal approximately 2.8 Hz.

Type	A mm	B mm	C mm	Working height H mm	+/- travel	max. load Kg** at an air pressure of	
						4 bar	6 bar
0.125*	76	72	72	77	+/-2.0	39	58
0.15*	76	72	72	77	+/-2.0	67	100
0.25*	120	182	110	87	+/-2.5	113	170
0.5	130	198	129	100	+/-2.5	267	400
1	200	275	200	100	+/-2.5	633	950
1.5	230	305	230	100	+/-3.5	1,017	1,526
2	260	350	260	100	+/-2.5	1,420	2,130
2.5	300	390	300	100	+/-3.0	1,967	2,950

* Natural frequency vertical approximately 3.0 Hz, horizontal approximately 3.5 Hz
 ** When selecting the size of air spring please select an air pressure of 4 bar.

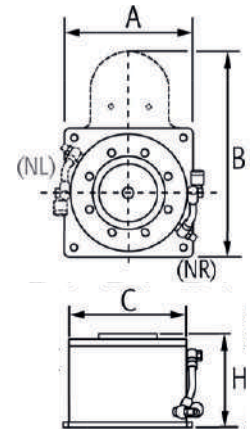

TYPE SERIES BiAir® -ED/-HE/-HE-MAX IN CAST ALUMINIUM

Natural frequencies vertical BiAir® -ED approx. 2.5 Hz
 BiAir® -ED-HE approx. 1.7 Hz
 BiAir® -ED-HE-MAX approx. 1.2 Hz
 Natural frequencies horizontal BiAir®ED approx. 2.8 Hz
 BiAir® -ED-HE approx. 2.8 Hz
 BiAir® -ED-HE-MAX approx. 2.8 Hz

Type	Working height H in mm			ØA mm	B mm	ØC mm	+/- travel mm	max. load Kg* *at an air pressure of	
	BiAir®-ED	ED/HE	ED/HE-MAX					4 bar	6 bar
0.5	157	307	-	120	216	129	+/-2.5	267	400
1	157	307	509	172*	288	200	+/-2.5	633	950
1.5	157	307	509	212*	305	230	+/-3.5	1,017	1,526
2	157	307	509	226*	335	260	+/-2.5	1,420	2,130
2.5	157	307	509	271*	378	300	+/-3.0	1,967	2,950
3	157	307	509	348*	467	382	+/-2.5	3,413	5,120
4	157	307	509	490	605	530	+/-2.75	6,573	9,860
5	157	-	509	747	875	798	+/-3.5	15,573	23,360

* For the sizes 1 to 3 of series ED/HE-MAX the ØA is the same as ØC (piston diameter)
 ** When selecting the size of air spring please select an air pressure of 4 bar.

Note

- The maximum permissible movement amplitude in the horizontal plane is between approximately 1 to 2 mm depending on the size of the air spring.
- In addition to the standard solutions listed here we also offer numerous air springs with a larger stroke and lower natural frequency.
- Powder coated air springs are also available in other RAL colours on request.
- Permissible temperature range: -20 °C to +80 °C
- If you have any questions please contact us, we would be happy to advise you.

Right to make technical changes is reserved.

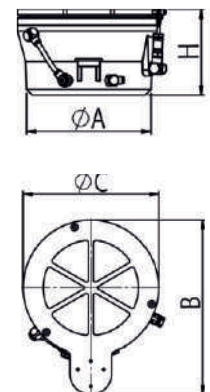

MPN

Mechanical pneumatic level control for Bilz air springs

Bilz mechanical pneumatic level control for air spring systems with FAEBI® and FAEBI®-HD rubber or BiAir® membrane air springs. Powerful vibration insulation at very high level consistency.



Mechanical pneumatic level control **MPN**

Bilz level control systems are significant components in the optimum function of vibration insulation using FAEBI® and FAEBI®-HD rubber or BiAir® membrane air springs. They prevent impermissible and undesired deflection of the insulators or an out-of-level condition of the machine that can be caused by load changes on an air spring mounted machine or system. Rapidly adding or venting air enables the air pressure within the air spring to be matched to the respective load, automatically controlling the height of the individual air springs. This enables the highest degree of stability and effective insulation even with changes in the centre of gravity.

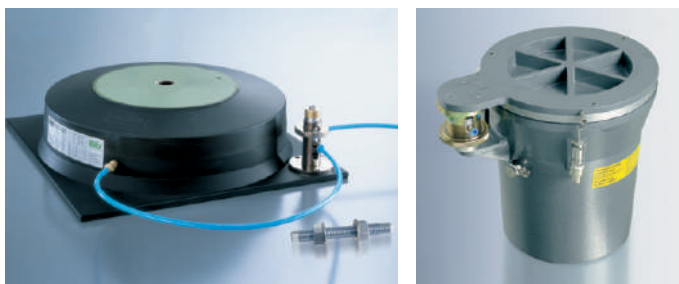
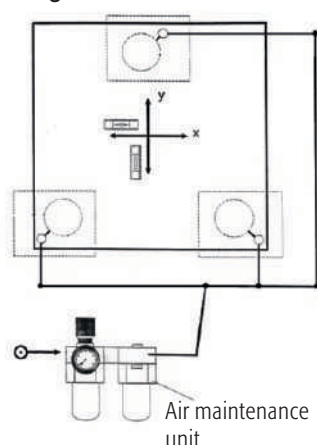

Fig. 1



Valve functions

The level is continuously sensed using the plunger. The position of the plunger is directly applied to the slide valve and the air spring is either pressurized or vented. The target level is adjusted by turning the knurled adjustment ring. The height and level of the machine is adjusted using three valves.

Design

At least three air springs are controlled (Fig. 1). If more insulators are required due to reasons of design or load, the system must still be worked in three controlled groups, as otherwise the system is statically overdetermined. This is achieved by using multiple insulators in parallel as a group (Fig.2). An additional air maintenance unit is installed upstream of the control valves to prepare the compressed air.

Fig. 2

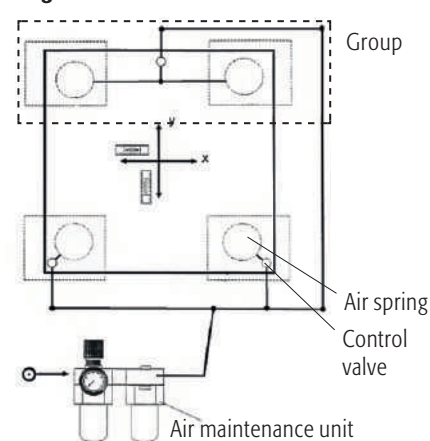

MPN-LCV



Very robust galvanized proportional valve. Level accuracy is approximately $\pm 1/10$ mm. **Suitable for Bilz FAEBI®, FAEBI®-HD and BiAir® air spring insulators.**

Available in the following versions:

- MPN-LCV: Standard version of the LCV with hard metal discs
- MPN-LCV-KURZ-Pad-A: Shortened version of the LCV with plunger insulation pad

MPN-PVM



High-precision yellow chromed proportional valve. Level accuracy is $\pm 1/100$ mm. **Suitable for Bilz BiAir® air spring insulators.**

Available in the following versions:

- MPN-PVM: Standard version of the PVM with carbide washers
- MPN-PVM-KURZ-Pad-A: Shortened version of the PVM with stem insulation pad

Note

- Supplied as a complete set which includes the 3 control valves and all necessary hose lines and connectors. All components are also individually available as spare parts.
- In addition to the standard solutions listed here we also hold special versions with regard to material, flow, accuracy and restoring force.
- On the LCV variant the air flow can be reduced using the throttle valve should the control system tend to overshoot. The PVM variant can also be fitted with a throttle valve as an option.
- If you have any questions please contact us, we would be happy to advise you.

Vibration insulated tables

Individually tailored to your requirements.

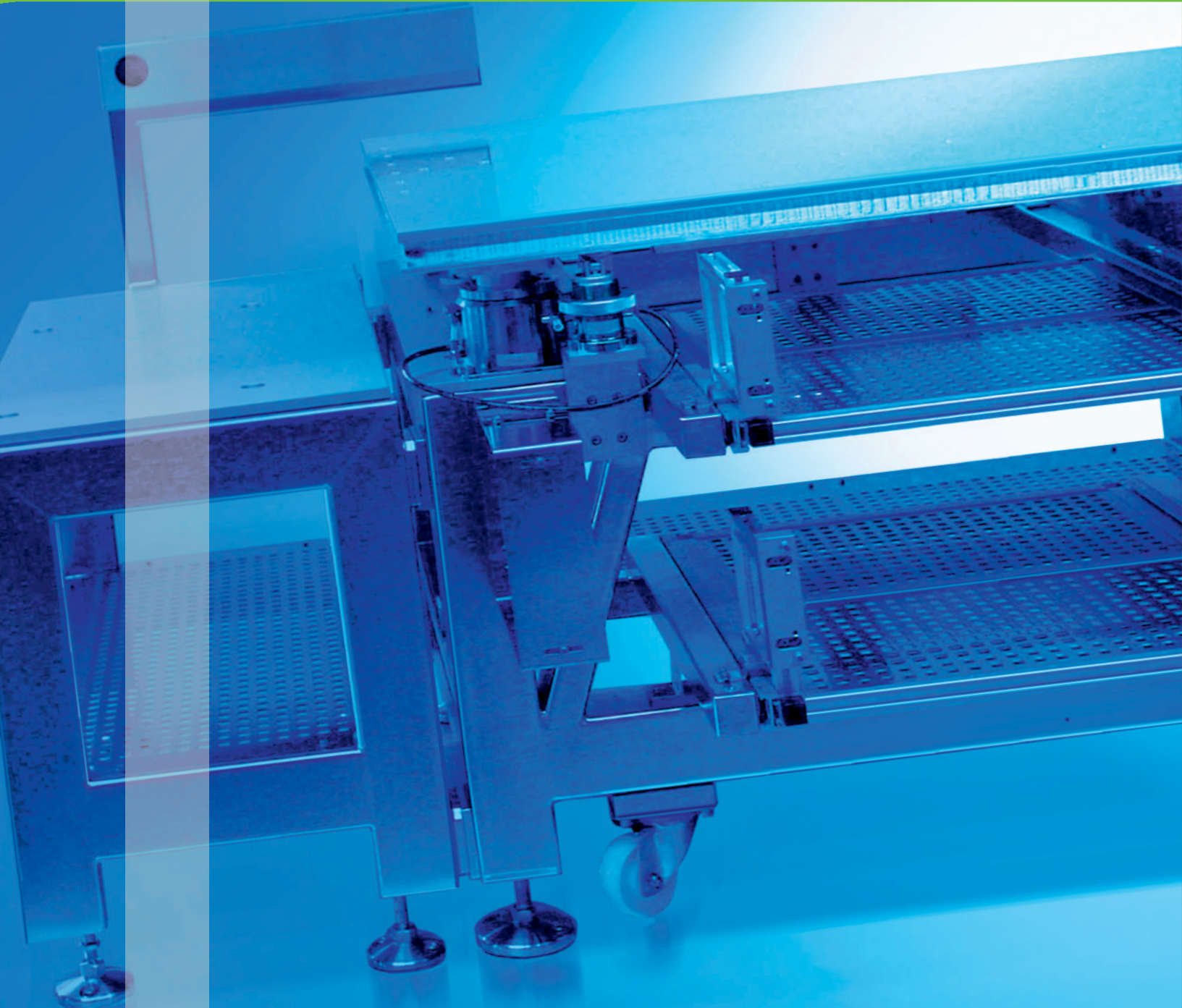



LTH laboratory table

Particularly robust and resistant, dynamic applications

Product properties

- Adjustable table feet
- Rigid, welded steel subframe
- BiAir® membrane air spring (vertical natural frequency approximately 3 Hz) between the subframe and table top
- Mechanical-pneumatic level control (level accuracy $\pm 1/100$ mm or $\pm 1/10$ mm, depending on the valve used)
- Table top made from hard stone with a ground finish
- Painting as desired by the customer
- Working height 76 cm

Applications

- Vibration-sensitive measuring and testing equipment
- Laser equipment
- Optical and electronic instruments
- Scales
- Medical instruments

Technology

The Bilz laboratory table LTH is a vibration insulated work place and can be used for all applications where vibrations and/or changes in level cause sustained disturbances to the experiment or work.

Disturbing vibrations from the environment are isolated by means of highly effective membrane air spring insulators and the solid hard stone plate.

At the same time the mechanical-pneumatic level control automatically ensures that the level is retained to an accuracy of up to $\pm 1/100$ mm even with load changes.

The maintenance unit for compressed-air conditioning is included.

LTH LABORATORY TABLE STANDARD SIZES

Dimensions	LTH 60-50	LTH 80-60	LTH 100-63	LTH 90-75	LTH 100-80	LTH 100-100	LTH 120-80	LTH 150-100	LTH 200-100
Width [mm]	600	800	1,000	900	1,000	1,000	1,200	1,500	2,000
Depth [mm]	500	600	630	750	800	1,000	800	1,000	1,000
Thickness [mm]	100	120	100	100	140	160	160	190	220
Working Height [mm]	760	760	760	760	760	760	700	760	760
max load [Kg]	250	250	300	360	700	700	700	1,800	2,800



LTO optical table

Excellent quality and functionality, dynamic applications

Product properties

- As LTH
- Optical table tops:
 - HD steel honeycomb core with high natural damping, cover plate without thread insert
 - HDT as HD, but with thread inserts
- Variants: Standard, clean room (base plate in stainless steel)
- Also available with BiAir® OC or BiAir® PAS as an option
- Working height 76 cm

Description of the table tops:

- Cover plate: Stainless steel 3 mm, magnetic or non-magnetic, anti-reflective.
- Base plate: Steel sheet 3 mm
- Clamping hole grid: 25 mm (standard)
- Core: HD/HDT: Steel honeycomb made of galvanised 0.5 mm steel sheet, precision formed, bonded with specifically matched resin
- Thread inserts (HDT): Floating mounted threaded inserts M6, closed sleeves prevent any contact with the table core. Capability to displace the clamping bolts by 0.5 mm whilst simultaneously inclining by $\pm 3^\circ$. Maximum depth of thread 30 mm.

Applications

- Construction of laser optical systems and interferometers
- Special microscopes

Technology

Work places from Bilz are distinguished by their excellent quality and functionality. Optical work places should offer optimum rigidity and damping with low density. Bilz LTO honeycomb tops are optimised in regard to their damping response so that the usual high resonance amplitude in the higher frequency range are attenuated by the tables in the HD series by their natural damping.

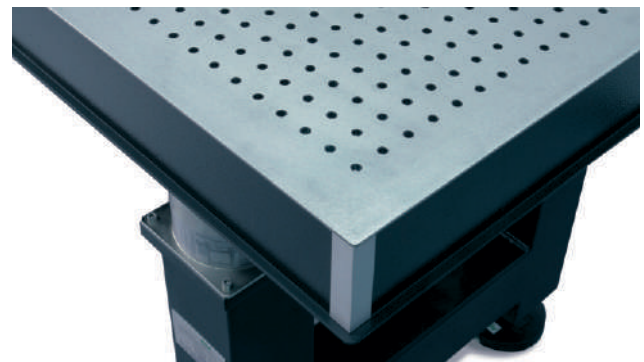

LTO OPTICAL TABLE STANDARD SIZES

Dimensions	LTO 60-50	LTO 90-60	LTO 120-60	LTO 150-90	LTO 200-100	LTO - 240-120	LTO 500-150
Width [mm]	600	900	1,200	1,500	2,000	2,400	3,000
Depth [mm]	500	600	600	900	1,000	1,200	1,500
Thickness [mm]	100	100	100	150	200	200	300
Working Height [mm]	760	760	760	760	760	760	760
max load [Kg]	150	200	300	500	500	750	750

Further dimensions are available on request

Right to make technical changes is reserved.

Individual design

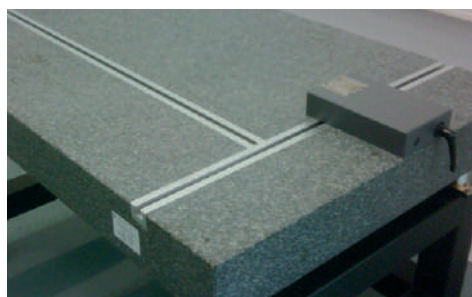

Compile the equipment features for the optimum laboratory table for your application:

- Additional holes/threads in the table top and the subframe
- Special sizes on request
- Can be equipped with metal guide rails on request

Options

Different frames in standard or special sizes

Cover hood

Arm rest

Different materials (wood, metal) and colors for:

- Doors
- Base plates/inserted plates
- Housing

Wooden plate:

- Different sizes
- Cutout
- Rounded corners

Holders for monitor, keyboard, mouse

Set of rolls

Levelling elements

Profiles and brackets for additional components

Powder coating in RAL colors

Insulators

- Level control (mechanical or electronic)
- Accessories (e.g. compressed-air control)
- Insulators perfectly integrated in the subframe



BiAir®



FAEBI®

Subframe

Levelling elements and rollers are available in various different designs and sizes.

BILZ-VITAP® Vibration insulating table platform

Product properties

- Portable, robust, powder coated metal housing with integrated Bilz rubber air springs FAEBI® or optionally with Bilz membrane air springs BiAir®
- Equipped with very simple through to very convenient Bilz level control systems
- A ground-finished hard stone plate lies on the insulators as a support base and solid base mass
- Available with and without a connection to an external compressed air supply

Applications

- For very light and very small measuring or test equipment
- Weight range up to 200 kg
- Optical devices, optical microscopes, microscopes with a CCD camera, inspection microscopes, small surface roughness and roundness measuring equipment, hardness testers, analytical balances, applications in industrial production environments, laboratories and measuring rooms up to clean rooms. Also suitable for the portable use of these measuring devices.

VITAP® -F

With long-term tried and tested Bilz FAEBI® rubber air springs with non-return valve. Integrated hand pump, no compressed air supply necessary.

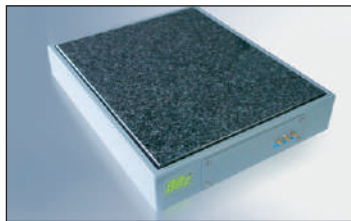

VITAP® -FP

With long-term tried and tested Bilz FAEBI® rubber air springs with precision pressure control for convenient height adjustment. Connection to an external compressed air supply.

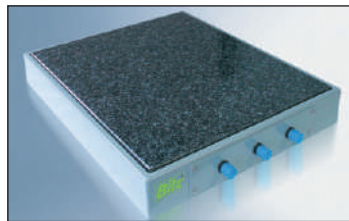

VITAP® -BM

With highly efficient Bilz BiAir® membrane air springs and with mechanical-pneumatic level control (MPN) with automatic level compensation in response to load changes. Connection to an external compressed air supply.

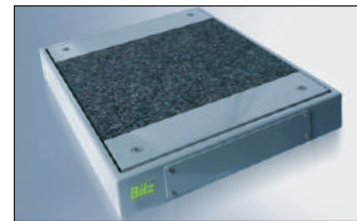

TECHNICAL DATA VITAP-F, VITAP® -FP, VITAP® -BM

	Item No.	Dimensions mm Platform box	Dimensions mm Installation surface	Height mm	Load capacity kg	Natural frequency Hz	Compressed air supply
VITAP® -F 50-40	56-0008	540 x 440	500 x 400	99 +/-1.5	60	4.5-6	autonomous/air pump
VITAP® -F 60-50	56-0009	640 x 540	600 x 500	99 +/-1.5	130	4.5-6	autonomous/air pump
VITAP® -FP 50-40	56-0010	540 x 440	500 x 400	99 +/-1.5	60	4.5-6	4 bar/air pressure network
VITAP® -FP 60-50	56-0011	640 x 540	600 x 500	99 +/-1.5	130	4.5-6	4 bar/air pressure network
VITAP® -BM 50-40a	56-0006	540 x 440	500 x 400	99 +/-1.5	75	2.5-3	6 bar/air pressure network
VITAP® -BM 50-40b	56-0005	540 x 440	500 x 400	99 +/-1.5	150	2.5-3	6 bar/air pressure network
VITAP® -BM 60-50a	56-0002	640 x 540	600 x 500	99 +/-1.5	150	2.5-3	6 bar/air pressure network
VITAP® -BM 60-50b	56-0003	640 x 540	600 x 500	99 +/-1.5	200	2.5-3	6 bar/air pressure network

Right to make technical changes is reserved.

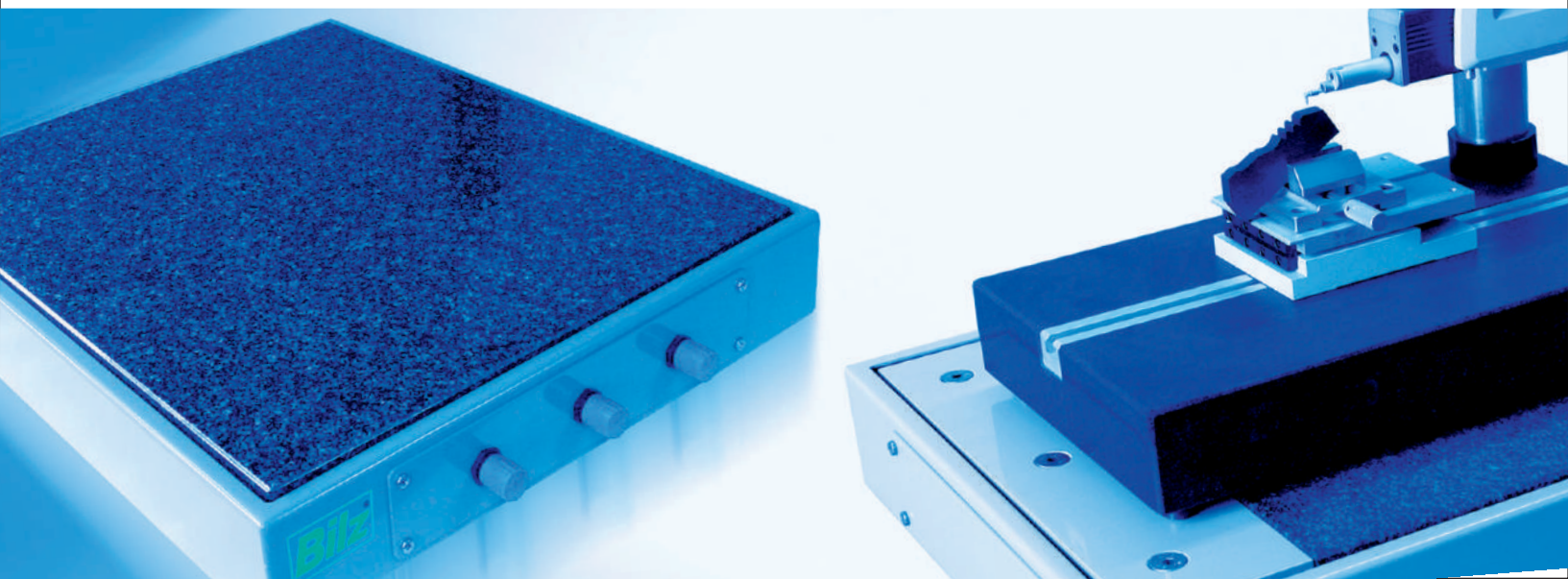

Isolated Machine Foundations

- Vibration foundation with Insulations Pad sets
- Vibration foundation with Rubber Air Spring FAEBI & Level Control
- Vibration foundation with BiAir Membrane Air Spring & Level Control



DIRECT INSULATION

Direct insulation means that vibration insulators are fitted directly under or in the machine, usually at the same locations as the available installation points.

Direct insulation requires that the machine bed or base frame has sufficient intrinsic rigidity and that it will not warp or twist due to elastic mounting. In addition the machine geometry must allow the suitable arrangement of the insulators.

INDIRECT INSULATION

Machines whose intrinsic rigidity is not sufficient for direct insulation require a rigidly designed intermediate construction to be fitted between the insulators and the machine.

This method also allows the positioning of the insulators to be optimised for the application.

Depending on

- Machine dimensions,
- Machine centre of gravity,
- Dynamic forces acting on the machine,
- Permissible machine movement,
- Requirements on the insulation,
- Mobility (flexible installation site),
- Attachment parts or feeds,
- Type of installation site (for example permissible floor loading, installation in above ground floors of a building),

This is achieved either by providing a block foundation made of concrete a steel platform or a cast plate. In this case the insulation is referred to as indirect insulation.

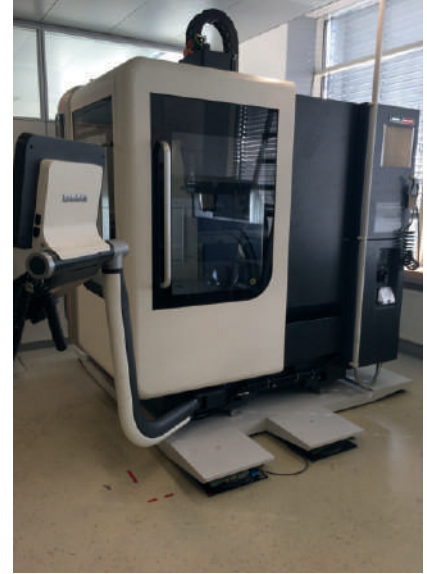

FOUNDATION INSULATION

Indirect vibration insulation of a machine or system enhances the natural rigidity and leads to a significant improvement of the dynamic behaviour in response to large changes in load and travel distances. The exact design of the foundation according to the machine properties ensures an economic solution for the long-term and trouble-free operation of the system.

We have many years and a wide range of experience in the design and projecting of machine foundations. We therefore offer all of the necessary services from single source:

- Vibration analysis on site
- Simulation
- Vibration insulation design
- Design and calculation of the foundation block
- Creation of the complete documentation (such as tender documents, formwork and reinforcement plans)
- Construction supervision
- Installation and commissioning of the vibration insulators

Your benefits from Bilz foundation insulations:

- The increased machine rigidity enables effective vibration insulation even with large machines and systems. This results in increased precision, receiver insulation and protects the machine surroundings.
- Reduction of the vibration amplitude by adding additional mass or moment of inertia and lowering of the centre of gravity. This results in electronic components, control, bearings, etc., enduring less stress and the quality of the results are significantly improved, in particular for applications where the level is critical.
- Smaller relative movements of individual machine components or attachments (such as robots, material feeds, etc.)
- Reduction of the size of the foundation compared to the foundation design without vibration insulation.
- All-round service from one single source; fewer interfaces and contacts.



Cast foundation block

Vibration foundation with insulations pad sets

Multiple layering of Bilz insulation pads can achieve significantly reduced natural frequencies and therefore considerably increase the insulation effect compared with a single layer of insulation pads.

These pad sets are particularly suitable for large machines and sprung foundations. The vibration insulation and damping properties of these insulation pads remain unchanged even after years of dynamic loading.

Bilz insulation pads are resistant against the most common greases, oils, coolants, cleaning agents as well as acids and alkalis.

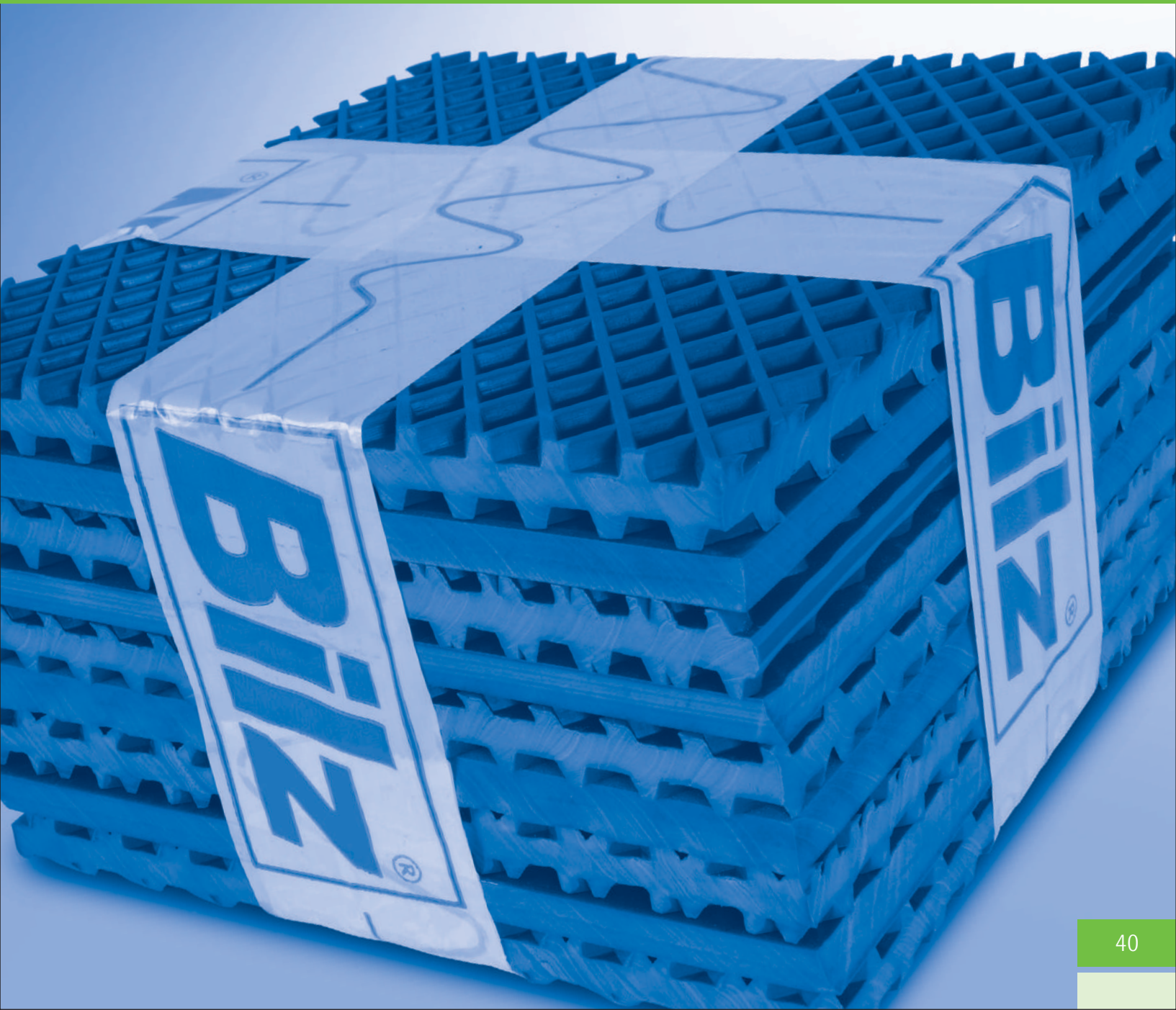

Insulation pad sets

Application

- Effective insulation pads for highly dynamic machines and foundations.
- The permissible load capacity of a pad lies between 5 and 40 Kg/cm² depending on the application. The number and size of the insulating layers and the required distribution of the pad sets is determined specifically for the application by Bilz.

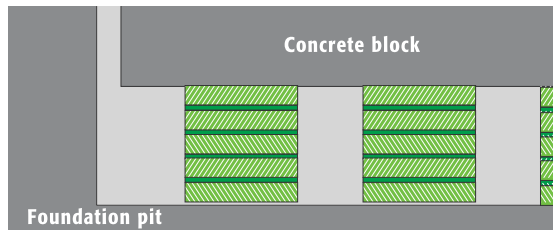

For further information contact us to arrange a personal consultation.



Foundation pit with Bilz insulation pads laid out

NATURAL FREQUENCY

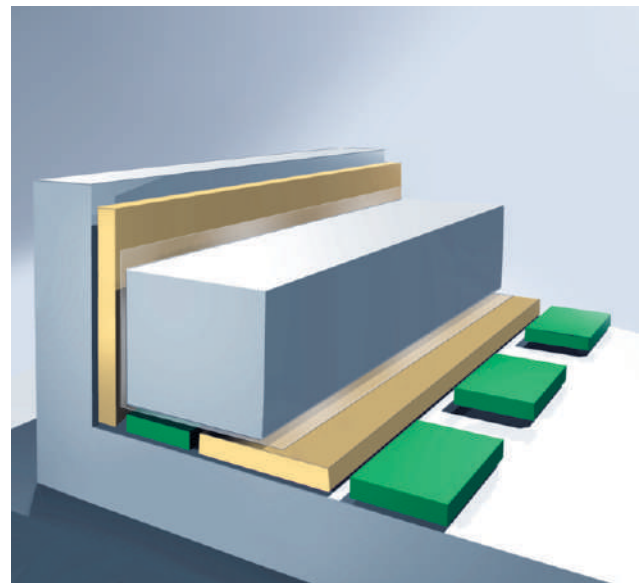
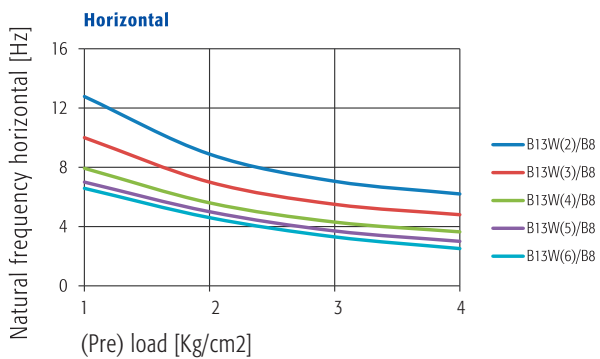
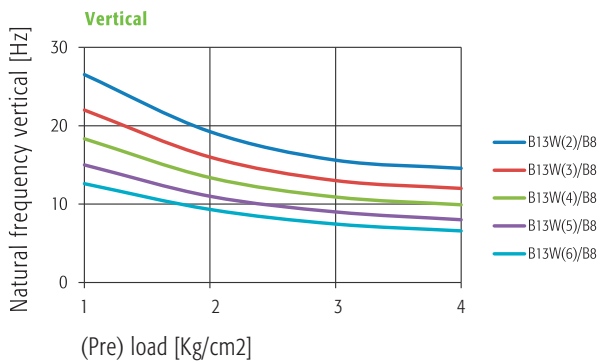

Type	Thickness unloaded mm	Natural frequency vertical Hz	Natural frequency horizontal Hz
B13W/B8, 2-layer	34	14.5 - 26.5	5.5 - 12.5
B13W/B8, 3-layer	55	12.0 - 22.0	4.5 - 10.0
B13W/B8, 4-layer	76	10.0 - 18.5	3.5 - 8.0
B13W/B8, 5-layer	97	8.0 - 15.0	3.0 - 7.0
B13W/B8, 6-layer	118	6.5 - 12.5	2.5 - 6.5

APPLICATION

Installation of a vibration foundation in an automotive plant for receiver isolation of a milling machine located opposite the press shop. Total mass of the foundation block 1,200 t.

Image 1, 2, 3: Design with Bilz isolation pads (black) and intermediate spaces with mineral fiber isolation board.

Image 4: Covering of the entire surface with construction foil, then with hard fiber boards. Bonding the overlapping areas.

Image 5, 6: Installation of the reinforcement.

Image 7, 8: Pouring the concrete.

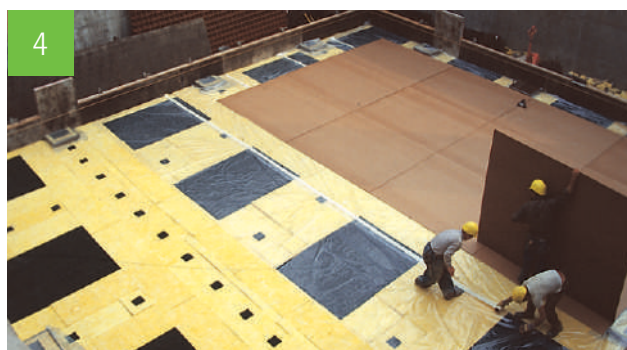
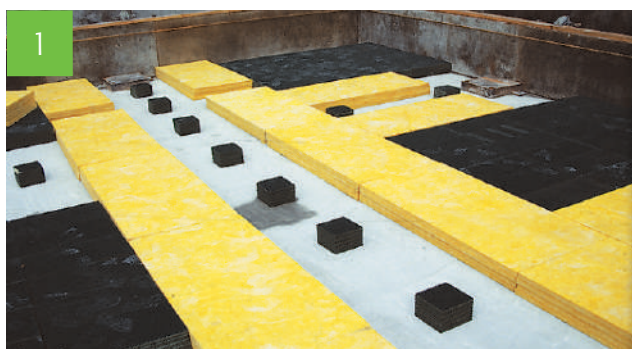

Vibration foundation with FAEBI®

Application example:

Foundation isolation with FAEBI rubber air springs and level control.
Implementation with pre-cast concrete slabs.

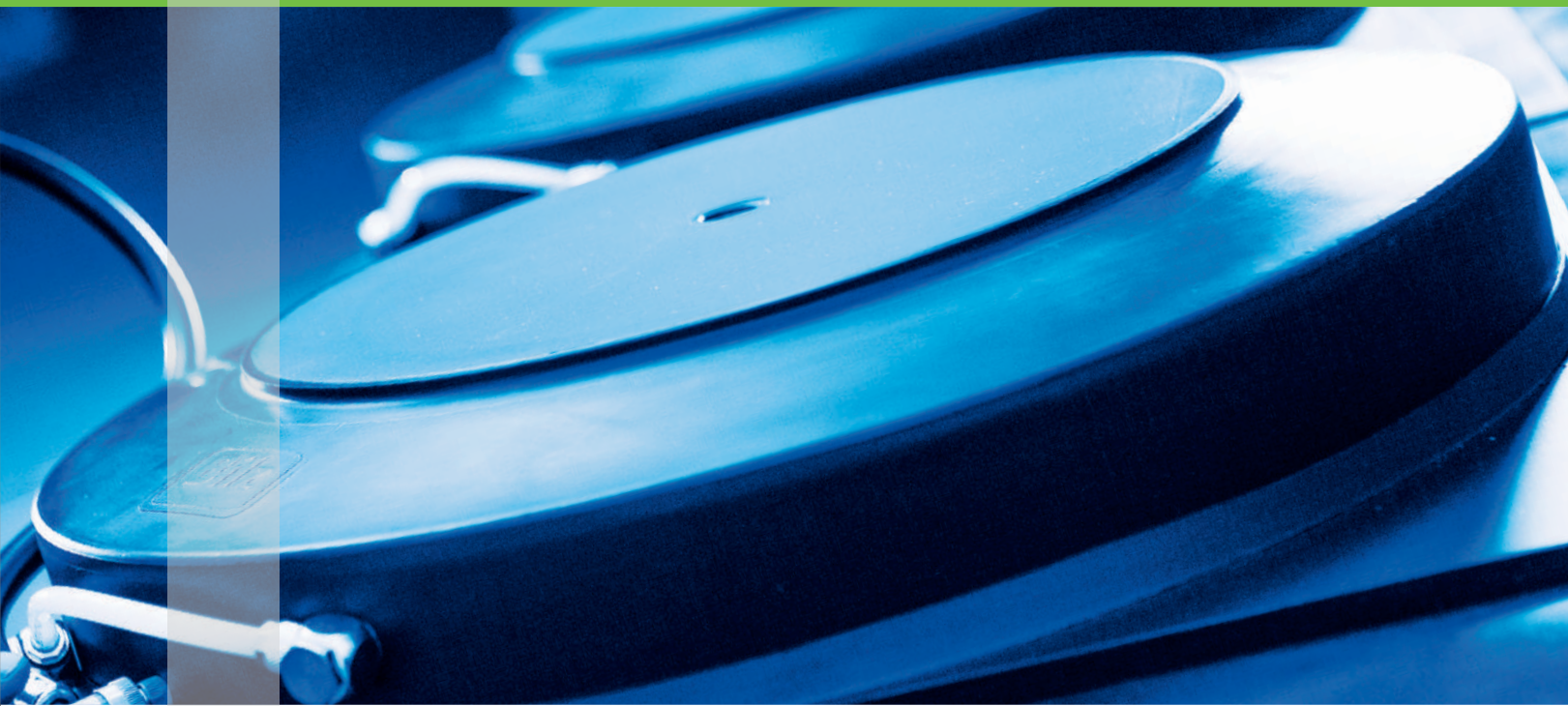

Bilz scope of supply and services

8 x Bilz FAEBI® 580 HD with mechanical-pneumatic level control MPN-LCV

Planning services

- Creation of the foundation
- Static calculations
- Formwork and reinforcement plans
- Steel and steel bending schedule

Requirements

- A maximum of 3 weeks loss of production.
- Special shape 5 corner
- Tight space conditions and entry to the inspection channel through the foundation block
- Extremely small allowable horizontal movements of the machine
- Reliable source isolation for suppressing the disturbing vibrations in the adjacent building, 2. floor, from 10 Hz.

APPLICATION

Punching machine, machine weight including the tool and accessories approximately 23 t, dynamic forces vertical approx. 60 kN, horizontal approx. 30 kN, foundation block approx. 5.1 x 3.5 x 1.0 m, weight approx. 40 t.

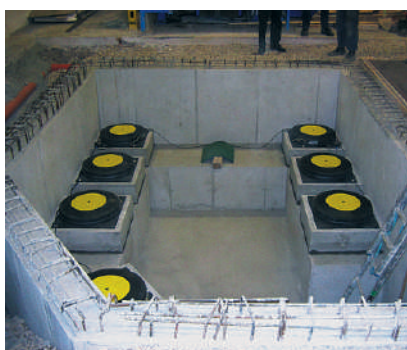

Vibration foundation with BiAir®

Application example:

**Foundation insulation with BiAir membrane air springs and level control.
Implementation with pre-cast concrete slab.**

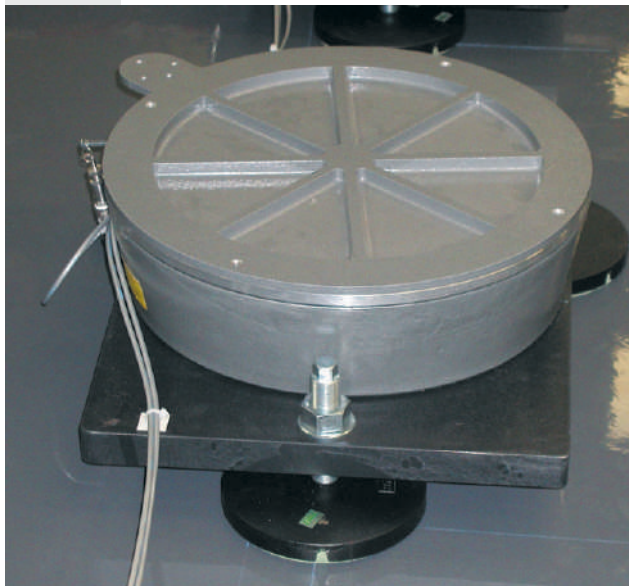
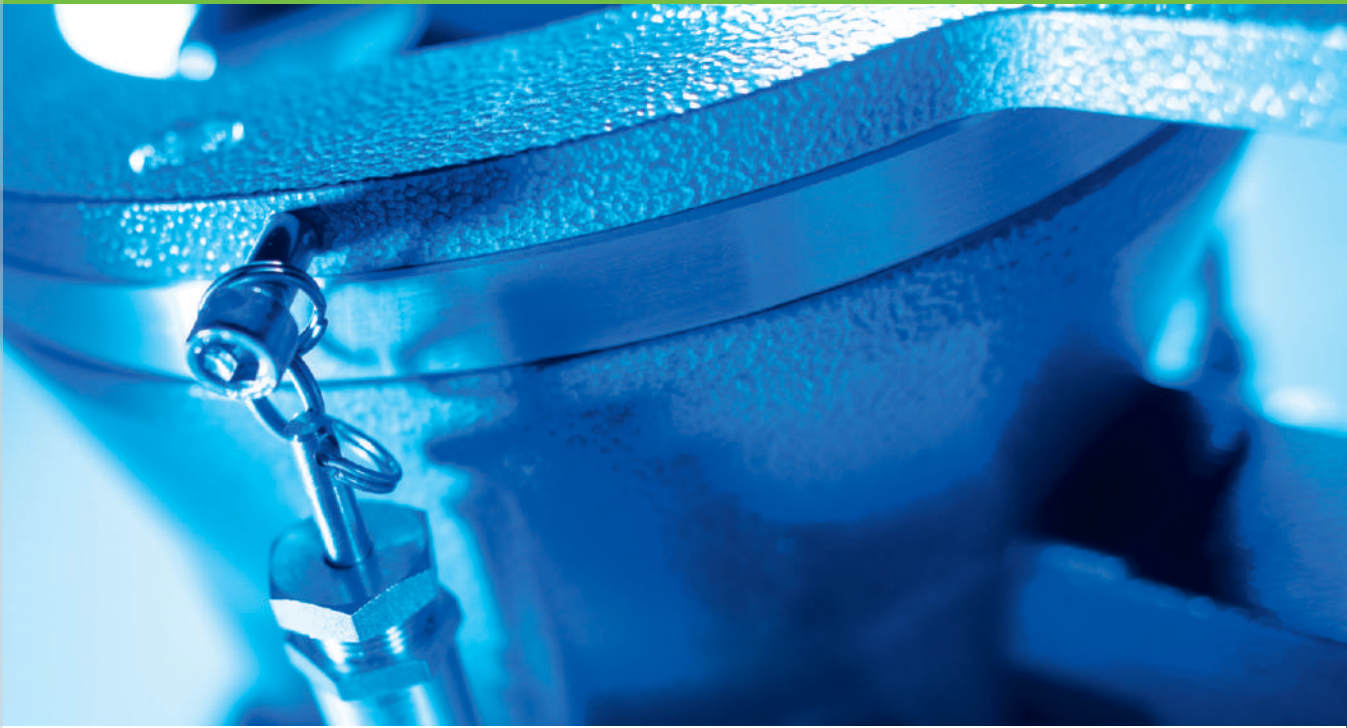

The foundation insulation using low-frequency BiAir® membrane air springs enables an optimum insulation effect. Unlike with the use of pad sets or steel springs the adjustable level of the foundation block automatically resets itself in response to load changes through the level control.

Bilz scope of supply and services

8 x Bilz membrane air springs BiAir® 4-ED with mechanical-pneumatic level control MPN-LCV.

Particular general conditions

The processing accuracy required of the roller grinding machine cannot be met due to disturbing influences from adjacent machines and an overhead crane rail. Large travel distances and tools weighing up to 10t cause large load changes that necessitate the use of a fast, mechanical-pneumatic level control with a level accuracy of ± 0.1 mm.

APPLICATION

Gear grinding machine GLEASON PFAUTER P 1200 G,
machine weight incl. tool up to 25 t,
foundation block approx. 5.2 x 1.9 x 0.7 m, approx. 20 t

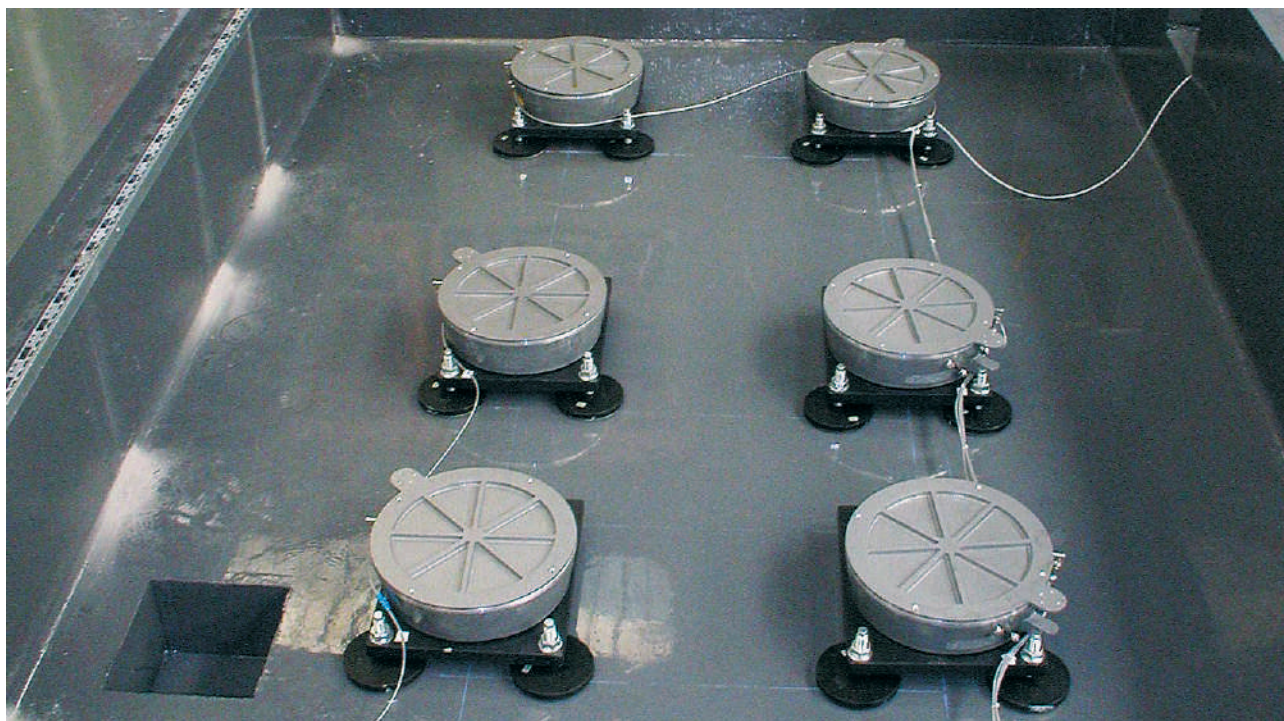

Vibration Insulation Platforms & Test Beds

Many applications require indirect insulation due to the requirements for effective insulation and level control or due to insufficient intrinsic rigidity. If foundation insulation is not possible as e.g.

- installation is on the elevated floors of a building,
 - the site of installation is of restricted space,
 - the site of installation should be flexible (mobility),
- then mounting the machine to a vibration insulated platform is a proven solution.

Usually either welded steel constructions or cast plates are used. Depending on the design of the platform the base of the machine is additionally extended and the centre of gravity is lowered by adding mass or the position of the insulators, which significantly enhances the stability of the overall system. In this way machines with a high centre of gravity and/or small base area can also be mounted to very low frequency and therefore soft insulators.

DESIGN EXAMPLES

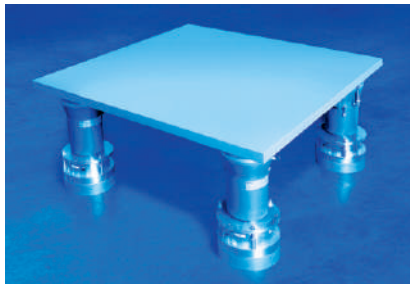

Basic platform

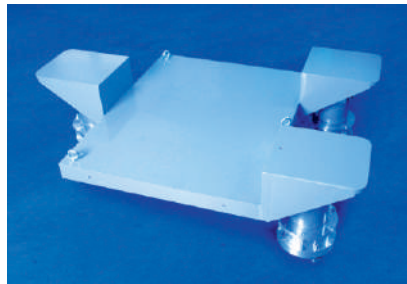

Platform for low installation height and for systems with a high centre of gravity

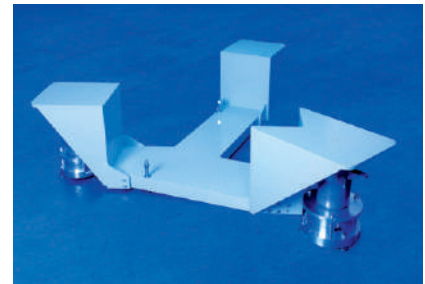

Platform for minimum installation height and for systems with a very high centre of gravity

SERVICES

- Frequency analysis and vibration measurement
- Simulations
- Design, manufacture, delivery, assembly and commissioning of total vibration insulation systems
- Manufacture, supply and installation of cast platforms
- Manufacture, delivery and installation of cast plates

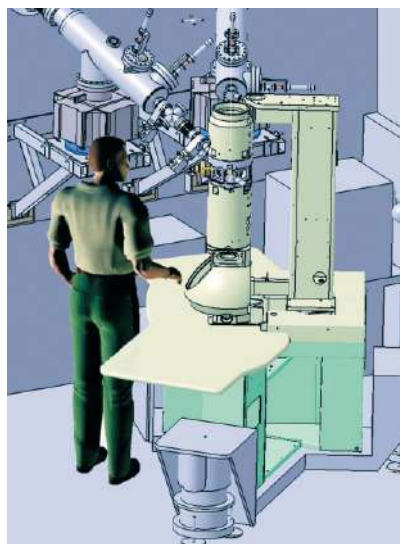

Platform for integration in double/clean room floors with additional mass for the reduction of vibration peaks

Vibration insulation of test beds

Parallel to the ever increasing demands on test beds and test systems for the automotive industry over recent years, the systems for vibration insulation have also been developing at the same pace.

Convenient and powerful air spring systems with level control have proven themselves ideal for very advantageous solution concepts. For the vibration insulation of test beds and aggregates with particularly high dynamic forces an additional seismic mass in the form of a concrete foundation is also needed.

APPLICATION EXAMPLES

- Engine test beds
- Articulated test beds
- Formula-1-test beds (BMW, Mercedes, Ferrari, Toyota, Renault)
- Gearbox test beds
- Acoustic test beds
- Rolling road test beds
- Shaker
- Sliding table
- Cylinder test beds
- Special test beds
- Hydropulser
- Road simulation test beds

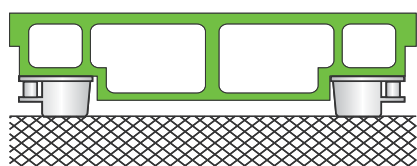
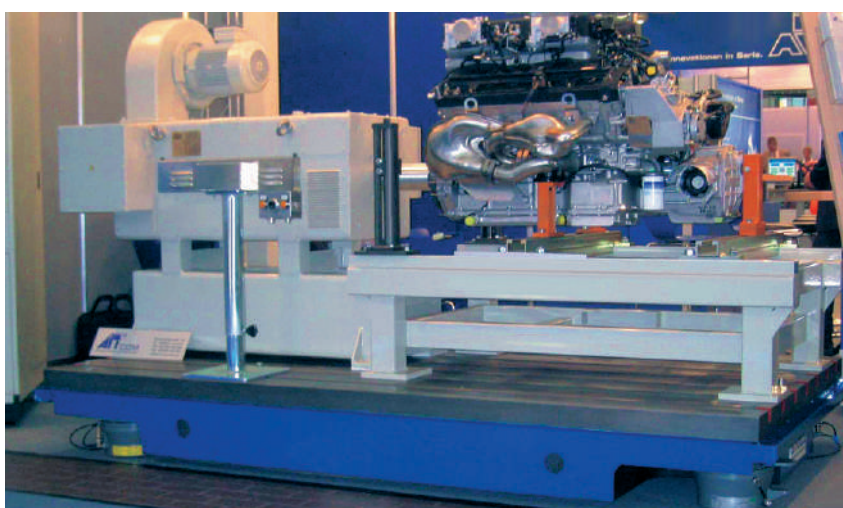

Vibration insulation cast steel platform



Vibration insulation concrete block or steel platform

Vibration foundations for special test beds

SERVICES

- Frequency analysis and vibration measurement
- Design, manufacture, delivery, assembly and commissioning of vibration insulation systems
- Production of static and reinforcement plans for foundation pits and -blocks
- Preparation of tender documents, price comparison, cost estimation



For further information contact us to arrange a personal consultation.

Measurement and Vibration Analysis

Measurement of vibrations and shocks using state of the art instruments – FFT Analyser and analysis software

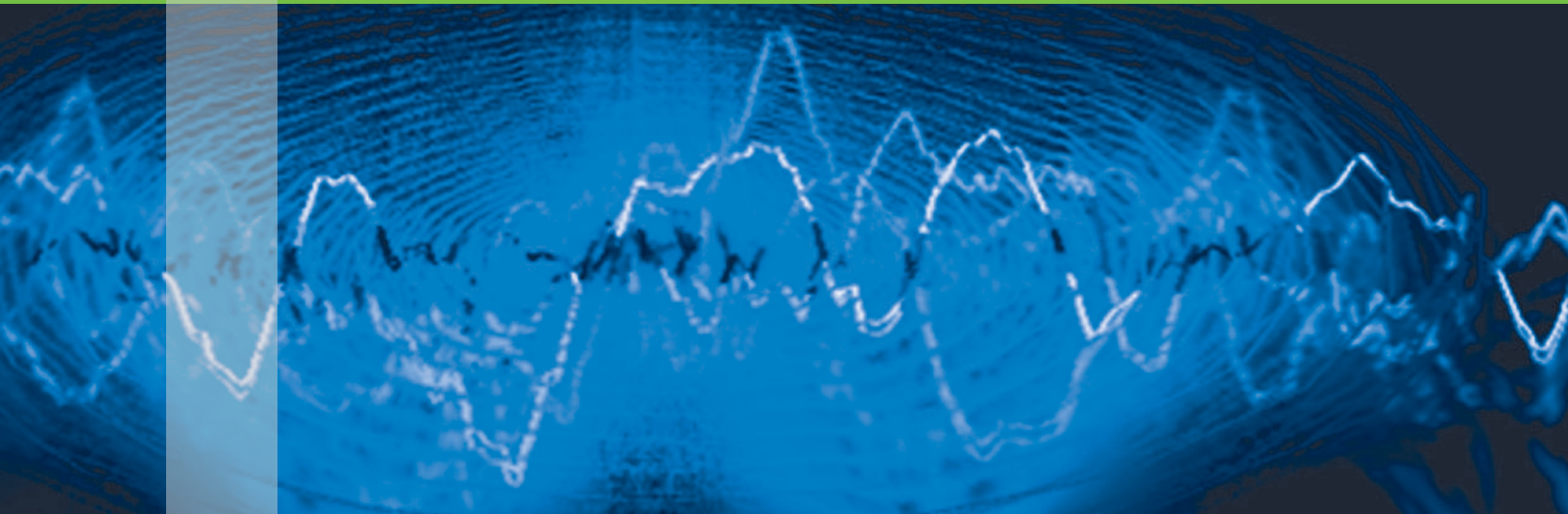

Assignment

Due to our decades of experience in the field of vibration technology and isolation, we guarantee you technically and economically reliable problem solutions. The on site measurement and analysis of vibration emissions and immissions is an essential part of our consulting services with regard to vibration and vibration insulation. Based on the measurement results, we develop vibration technical measures to comply with legally prescribed limits.

The assessment of periodic and non-periodic vibrations in the frequency range from 1 Hz to 80 Hz is e.g. based on the DIN 4150 "Vibrations in buildings; Effects on persons in buildings". Requirements and reference values are stated herein, in general the considerable disturbance of people in domestic properties and similar premises is to be avoided in order to comply with these regulations.

Procedure

In the first step the maximum value of the vibration levels for the three directional components x, y and z are determined. The largest of these three values KBF_{\max} is compared with the reference values A_U and A_O according to Table 1

- If KBF_{\max} is less than or equal to the (lower) reference value of A_U , then the requirements of this standard are met.
- If KBF_{\max} is more than the (upper) reference value of A_U , then the requirements of this standard are not met.
- For short-term impacts and those that do not occur often, the requirement of the standard is met if KBF_{\max} is less than or equal to A_O .

Another current example of the requirement for a vibration analysis is the storage of high-precision 3D-measurement machines, as well as other testing, measuring or grinding machines. Typically measurements must be carried out by such machines at the planned site, to ensure that existing ground vibrations do not exceed the permitted values (see Chart 1). To do this, the vibration acceleration is

determined within a given frequency spectrum (1–100 Hz), as a simple sum value measurement would provide insufficient information about the exact environmental conditions. The analysis of the acceleration time signals is carried out using a fast-fourier-analyser, which indicates the corresponding measurement value (vibration acceleration in g) for each frequency of the spectrum. If the disturbances (vibration interference) are out of the permissible range, the appropriate insulation can be determined with the help of our PC calculation program.

Very accurate vibration analysis in the lower frequency range are carried out with highly sensitive Geophones. Vibration speeds from below $0.01 \mu\text{m/s}$ in the range from 0.2 to 30 Hz can be recorded with the Geophones. Extremely precise measurements of vibration are necessary for an optimal and customer-specific design, particularly in the semiconductor and Nanotech industry as well as for high-precision 3D-measurement machines.

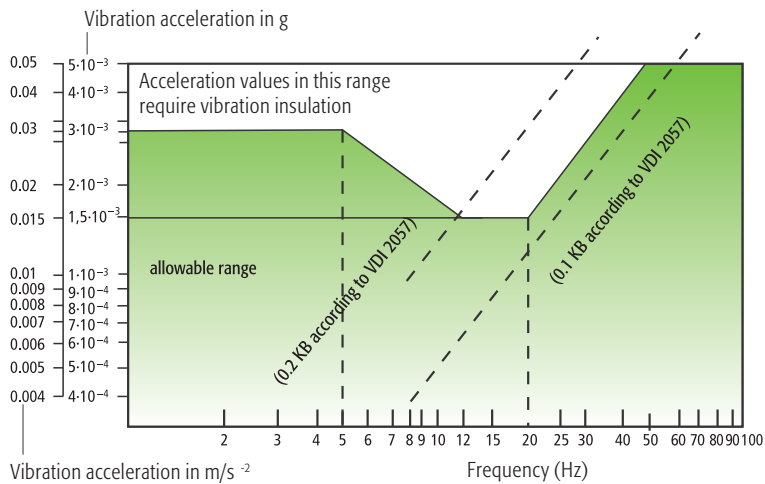

Chart 1: Example CMM limit curve

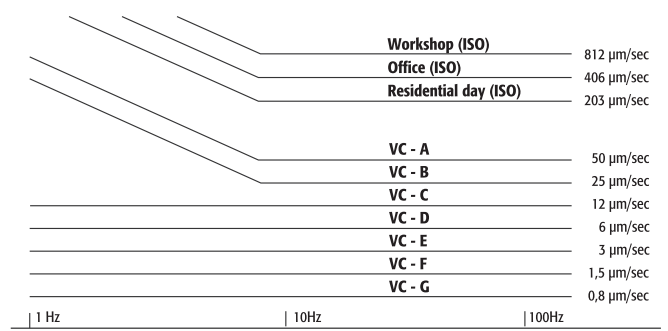

Chart 2: Vibration Criteria VC



FFT Analyser

REFERENCE VALUES A FOR THE ASSESSMENT OF VIBRATION EMISSIONS

in domestic property and similar premises

Line	Impact site	daytime			nighttime		
		A_u	A_o	A_r	A_u	A_o	A_r
1	Impact sites, in whose vicinity only commercial facilities and where appropriate are housed with the exception of where the owner and manager of operations, as well as supervisory and stand-by persons are housed (see Industrial estates § 9 BauNVO)	0.4	6	0.2	0.3	0.6	0.15
2	Impact sites, in whose vicinity mainly commercial facilities are housed (see Industrial estates § 8 BauNVO)	0.3	6	0.15	0.2	0.4	0.1
3	Impact sites, where neither predominantly commercial facilities nor predominantly domestic property are housed (see Core areas § 7 BauNVO, mixed areas § 6 BauNVO, village areas § 5 BauNVO)	0.2	5	0.1	0.1	0.2	0.15
4	Impact sites, in whose vicinity predominantly or exclusively domestic property is housed (see Pure residential areas § 3 BauNVO, General residential areas § 4 BauNVO, Small housing estates § 2 BauNVO)	0.15	3	0.07	0.1	0.2	0.3
5	Particularly vulnerable impact sites, for example in hospitals, sanatoriums, in so far as the are situated in those areas specially designated for them.	0.1	3	0.05	0.1	0.15	0.07

In brackets the areas of the Federal Land Utilisation Ordinance = BauNVO are specified, usually represented by the designations under line 1 to 4. A schematic equation is not possible because the designations under line 1 to 4 are only made after the grounds have been established to protect against exposure to vibration, the zoning of the area in the BauNVO takes into account however also other planning requirements.

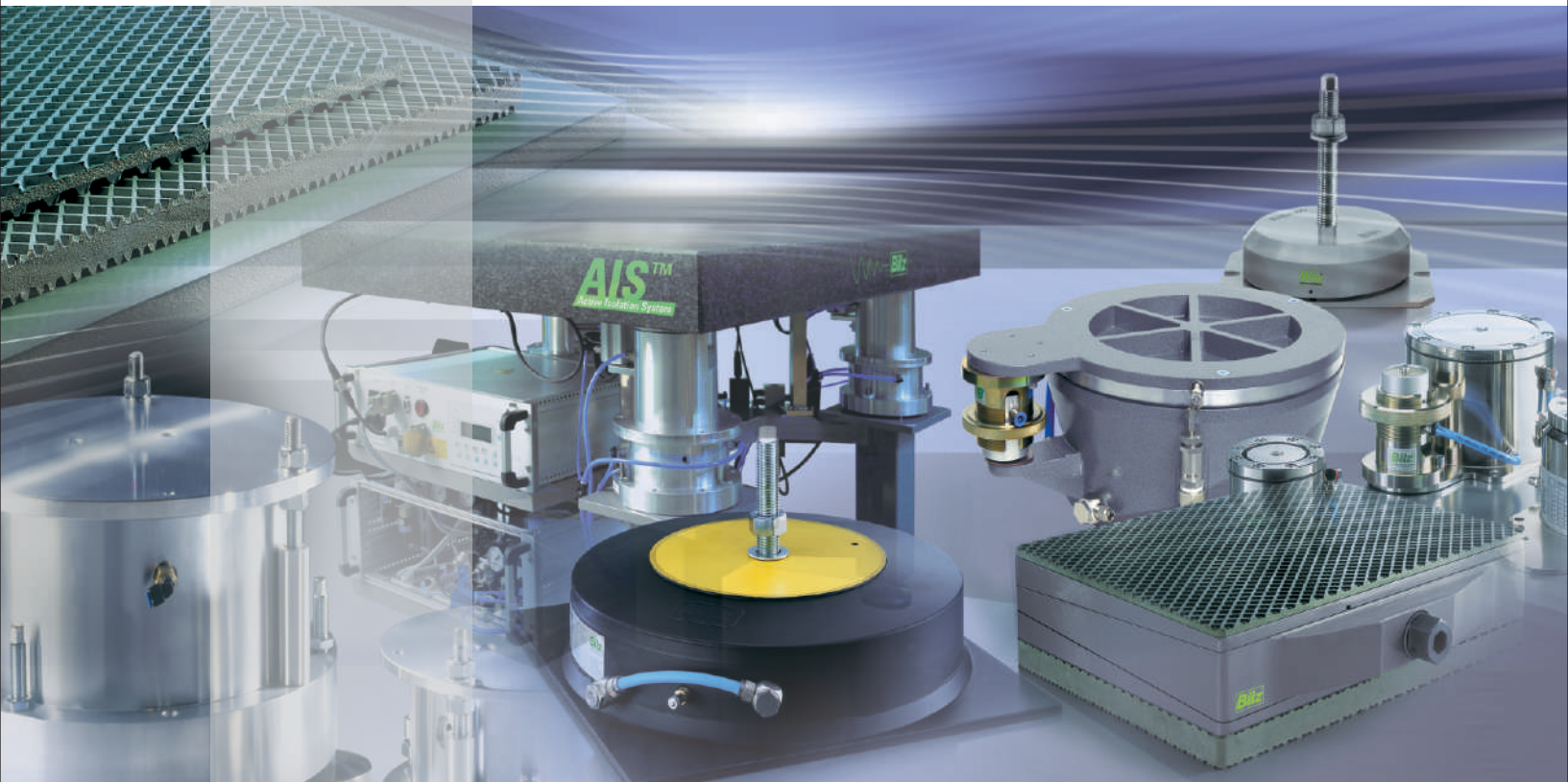

Bilz[®]

In Technical Tie up with Bilz Vibration Technology AG, Germany

Machine House (India) Pvt. Ltd.

Corp. Off. : D/1/18, MIDC, Ambad, Nashik - 422 010. INDIA
Works : W-82(A), MIDC, Ambad, Nashik - 422 010. INDIA
Phone : +91 253 2370662, 2382255
Mobile : +91 98223 95213, 99229 94859, 90110 38385
E-mail : bilzindia@gmail.com / info@antivibrations.com
Web : www.antivibrations.com